



ENVIRONMENT
AGENCY

BRE

constructing the future

Protective measures for housing on gas-contaminated land

Roger Johnson

Parkman Environment

BRE
Garston
Watford
WD25 9XX

Prices for all available BRE publications can be obtained from:
 CRC Ltd
 151 Rosebery Avenue
 London EC1R 4GB
 Tel: 020 7505 6622
 Fax: 020 7505 6606
 email:
 crc@construct.emap.co.uk

BR 414
 ISBN 1 86081 460 3

© Copyright BRE 2001

BRE is committed to providing impartial and authoritative information on all aspects of the built environment for clients, designers, contractors, engineers, manufacturers, occupants, etc. We make every effort to ensure the accuracy and quality of information and guidance when it is first published. However, we can take no responsibility for the subsequent use of this information, nor for any errors or omissions it may contain.

Published by
 Construction Research
 Communications Ltd
 by permission of
 Building Research
 Establishment Ltd

Requests to copy any part of this publication should be made to:
 CRC Ltd
 PO Box 202
 Watford WD25 7ZW

The Environment Agency, BRE and the authors cannot accept any liability for the use or interpretation of the contents of this manual. The Environment Agency's reference number for this manual is R&D Technical Report P336.

The author was:
 Mr Roger Johnson Parkman Environment

The principal contributor was:
 Dr Geoffrey B Card Card Geotechnics Limited

The project was guided by a Project Steering Group that comprised:
 Mr Michael Johnson DETR Building Regulations Division
 Mr Richard Hartless BRE
 Mr Douglas Laidler Parkman Environment
 Dr David Clinton Parkman Environment
 Mr Richard Owen Ove Arup and Partners
 Mr Peter Witherington ENSR International Limited
 Dr Bill Baker Environment Agency

The author would like to thank all those who contributed to the production of this manual. In particular the assistance from the following individuals and organisations is acknowledged:

Mr K Bratton	Wimpey Homes Holdings Limited
Mr J Cover	Bryant Homes Limited
Mr D Jones and Mr R Lotherington	Fairview New Homes Plc
Mr M Ford	National House Building Council
Mr T Clarkson	Sandwell District Council
Mr M Martin and Mr R Stevens	Prestige Air Technology
Mr P Culleton	Environmental Protection Group Limited
Mr R Edwards	Grace Construction Products Limited
Mr P Atchison	Monarflex Geomembranes Limited

The authors and the Project Steering Group acknowledge the support of the Environment Agency who funded the project and contributed to the content of this manual.

BRE material is also published quarterly on CD

Each CD contains BRE material published in the current year, including reports, specialist reports, and the Professional Development publications: Digests, Good Building Guides, Good Repair Guides and Information Papers.

The CD collection gives you the opportunity to build a comprehensive library of BRE material at a fraction of the cost of printed copies.

As a subscriber you also benefit from a 25% discount on other BRE titles.

**For more information contact:
 CRC Customer Services on 020 7505 6622**

Construction Research Communications

CRC supplies a wide range of building and construction related information products from BRE and other highly respected organisations.

Contact:

post: CRC Ltd
 151 Rosebery Avenue
 London EC1R 4GB

fax: 020 7505 6606
 phone: 020 7505 6622
 email: crc@construct.emap.co.uk
 website: www.constructionplus.co.uk

Contents

Foreword	iv
1 Introduction	1
1.1 Objective and scope	1
1.2 Manual layout and methodology	1
2 Principles of construction	2
2.1 Gas entry routes	2
2.2 Gas protective measures	3
2.2.1 Ground floor construction	3
2.2.2 Gas-resistant membranes	4
2.2.3 Open voids	4
2.2.4 Proprietary void formers	4
2.2.5 Granular blankets	4
3 New-build floor and sub-structure options	5
3.1 Beam-and-block floor with open void	6
3.1.1 Continuous membrane on top of slab	6
3.1.2 Access for the disabled – threshold detail	8
3.1.3 Stepped membrane at external wall	10
3.2 Suspended in-situ concrete slab with void former	12
3.2.1 Continuous membrane on top of slab	12
3.2.2 Access for the disabled – threshold detail	14
3.3 Raft or semi-raft foundation	16
3.3.1.1 Membrane on top of slab – external wall	16
3.3.1.2 Membrane on top of slab – internal wall	18
3.3.2.1 Membrane on top of slab with below slab ventilation layer – external wall	20
3.3.2.2 Membrane on top of slab with below slab ventilation layer – external wall (alternative)	22
3.3.2.3 Membrane on top of slab with below slab ventilation layer – internal wall	24
3.4 Membrane/damp-proof course details	26
3.4.1 Membrane not suitable as damp-proof course	26
3.4.2 Membrane suitable as damp-proof course	28
4 Gas protective measures in extensions	31
4.1 Beam-and-block floor with open void	32
4.2 Suspended in-situ concrete slab	34
5 Remedial measures in existing buildings	37
5.1 Methods of protection	38
5.2 Constraints	39
5.3 Venting the sub-floor and sealing the concrete oversite	40
5.4 Service entries	42
6 Specific details – gas-resistant membranes	45
6.1 Types of membrane	45
6.2 Advantages and limitations	45
6.3 Integrity testing	45
6.4 Protection during construction, jointing and sealing	46
7 Specific details – venting the sub-floor	49
7.1 Air bricks	49
7.2 Periscope vents	49
7.3 High level stacks	50
8 Specific details – granular blankets	53
9 Specific details – gas drains in granular blankets	55
10 Specific details – service entries	56
10.1 Beam-and-block floor with open void	56
10.2 In-situ concrete slab	58
10.3 Sealing service ducts	60
10.4 Top of slab services	62
10.5 External service entry	64
Bibliography	66

Foreword

The Government has estimated that an additional 3.8 million new homes will be required before the year 2016. This demand for housing will place considerable pressure on land supply. In order, therefore, to reduce further encroachment for development of rural areas or 'greenfield' sites, the Government is encouraging the use of land which has been developed previously: 'brownfield' land. The target set in DETR Planning Policy Guidance Note No.3 is that by 2008 at least 60% of the additional housing should be provided on brownfield land or through conversions of existing buildings. The previous use of many brownfield sites has involved the depositing of waste. As the organic content of the waste biodegrades, it can produce hazardous soil gases. The primary gases of concern are methane and carbon dioxide. Methane is a flammable, asphyxiating gas. If it is confined and ignited, it will explode. Carbon dioxide is a non-flammable, asphyxiating and toxic gas. Volatile organic compounds (VOCs) are also produced through the biodegradation of waste and may arise through the spillage of fuel and solvents.

The presence of hazardous soil gases is not limited to brownfield land. Methane and carbon dioxide may also occur on greenfield sites owing to the presence of naturally occurring organic deposits, for example peat and coal measures. Radon is also a natural soil gas that is formed when uranium that is present in many soils and rocks undergoes radioactive decay.

As the radon decays it forms short-lived radioactive particles; if inhaled over a period of time, this increases the risk of lung cancer.

The 1991 Building Regulation C2 requires that the occupants of buildings should be protected from the effects of gaseous contamination in the ground. The Approved Document that accompanies the Building Regulations refers to publications from DETR, BRE and BSI that provide guidance on methods of protection.

Two BRE Reports, *Radon: guidance on protective measures for new dwellings* (BR 211) and *Construction of new buildings on gas-contaminated land* (BR 212), describe the construction principles that need to be followed on sites where there are elevated levels of radon, methane and carbon dioxide.

Although all the published documents contain specific advice, there is the need for a manual that complements the published guidance (particularly BRE Reports BR 211 and BR 212) with practical details for the most common forms of construction for low-rise residential housing.

This manual provides regulators, designers, developers and other any other interested parties with guidance on the detailing and construction of passive gas protective methods.

The Environment Agency/NHBC R&D Publication 66 introduces the main issues associated with the safe development of housing on land affected by contamination. It describes the procedures necessary for achieving the safe development of housing on such land. It is also relevant where contamination identified within existing developments needs to be addressed.

Other publications

Guidance on site assessment

Methane: its occurrence and hazards in construction. CIRIA Report 130, 1993.

Measurement of methane and other gases from the ground. CIRIA Report 131, 1993.

Protecting development from methane. CIRIA Report 149, 1995.

Methane investigation strategies. CIRIA Report 150, 1995.

Interpreting measurements of gas in the ground. CIRIA Report 151, 1995.

Risk assessment for methane and other gases from the ground. CIRIA report 152, 1995.

Guidance for the safe development of housing on land affected by contamination. Environment Agency/NHBC R&D Publication 66, 2000.

Further guidance on site assessment is in:
Land quality – managing ground conditions.
NHBC Standards Chapter 4:1.

This manual should be read in conjunction with other published guidance, particularly:

The CIRIA series of guidance reports.

Passive venting of soil gases beneath buildings. Guide for design. DETR/Ove Arup, Partners in Technology, 1997.

Radon: guidance on protective measures for new buildings. BRE Report BR 211, 1999, 3rd edition.

Construction of new buildings on gas-contaminated land. BRE Report BR 212.

A list of useful guidance documents for further reading is in the Bibliography on page 66.

1 Introduction

1.1 Objective and scope

This manual is a practical guide to current good practice for the detailing and the construction of passive soil gas protective measures for new and existing residential development. It does not contain advice on the design of passive or active protective measures for specific gas regimes, nor does it provide information on active gas protective systems or in-ground protective measures external to the building, such as the use of venting trenches or barriers. The gases considered are principally methane, carbon dioxide and mixtures of the two. The sources of both gases are typically:

- fill or made ground containing biodegradable organic material;
- soils with a high organic content, eg peat;
- coal measures and/or underground mine workings;
- soil gas migrating from a nearby source.

The details are also applicable to radon and, subject to the suitability of the materials, VOCs.

This manual should be used only after the gas regime for a site has been fully characterised and it has been confirmed that the passive protective measures contained in the manual are appropriate. Passive protective measures are the combination of utilising the ground floor as a barrier against the ingress into the building of soil gas, and sub-floor venting which dilutes and disperses the soil gas.

The investigation and assessment of a soil gas regime for a specific site and the selection and design of an appropriate gas protective system or systems requires specialist advice from a suitably qualified and experienced engineer or scientist.

Every site is unique; this manual does not provide advice on the assessment of sites or the selection of the most appropriate protective measures. The reader must, therefore, make appropriate and specific assessments with a geotechnical and geo-environmental investigation.

Guidance on site assessment is in the publications listed opposite on page iv, and on page 66.

When applying the details in this manual, the designer must always check that the details for gas protection do not conflict with Building Regulations for other design and construction criteria, for example thermal insulation, accessibility or damp and water penetration.

1.2 Manual layout and methodology

The details are presented in this manual in the form of 'as constructed' details.

Individual sections show gas protection for the most common forms of foundation and floor used on residential development. The details of the gas protective measures were selected on the basis of:

- the practicability of construction and installation in a building site environment;
- the ability to prevent the ingress of gas into a building based on past performance.

Construction details beneath each detail identify the principal components. In addition, a list of *Watchpoints* offers practical information for installation and buildability. The user may wish to add further watchpoints as experience is gained with the detailing and construction of gas protective measures.

The manual includes:

- options for foundation and ground floor construction commonly encountered in low-rise housing;
- construction methods for extensions;
- remedial measures in existing buildings.

The manual also highlights the key components in each gas protective measure.

The details and construction on gas protective measures presented in this manual have been collated from a number of organisations and individuals who are experienced in the development of gas-contaminated sites with housing. Although there is a variety of permutations for installing gas protective systems, the contents of the manual are restricted to typical details for each application.

The organisations consulted were:

- consulting engineers responsible for the design of gas protective measures;
- residential developers and housebuilders;
- manufacturers and specialist installers of gas protective systems;
- building control authorities.

A project steering group reviewed and contributed to the contents of the manual.

2 Principles of protection

2.1 Gas entry routes

The primary cause of soil gas entering a building is the pressure difference that exists between inside and outside the building: this tends to draw soil gas into the building from the ground below.

This pressure differential has two primary origins:

Stack effect: In most houses, the internal temperature is generally higher than the temperature outside; this means that indoor air has a lower density than outdoor air. The indoor air rises up through the house and outdoor air is drawn into the house at lower levels. The resulting pressure difference also causes soil gas to be drawn into the house through any openings in the ground floor construction.

Venturi effect: As wind blows over a house, it creates a positive pressure on the windward side and a suction on the leeward side. Outdoor air enters the house (through openings such as windows, doors and cracks) on the windward side, and indoor air is drawn out on the leeward side. This reduces the indoor air pressure with respect to outside, causing soil gas to be drawn into the house through any openings in the ground floor construction.

Typically, soil gases can enter buildings through:

- gaps around service pipes;
- cracks in walls below ground and floor slabs;
- construction joints;
- wall cavities.

Soil gases can also accumulate in:

- voids created by settlement beneath the floor slab;
- in drains and soakaways;
- confined spaces within the building envelope, such as cupboards and sub floor voids.

Figure 2:1 shows the potential gas entry routes into a building and locations where gas may accumulate.

The following factors may cause soil gases to enter a building:

Gas-permeable materials

Voids that are integrated into the construction of the building, such as cavities in cavity wall construction, can also provide gas entry routes and pathways as well as locations where gas can accumulate.

Design practices

Buildings require adequate ventilation to minimise condensation and provide a healthy and comfortable living environment. For these reasons, it is impossible to design a completely gas-tight building that is fit for habitation. Where there are airflow pathways, there are potential gas migration pathways.

Construction methods

The process of constructing a residential building involves the fabrication of a wide variety of individual components. Inevitably, gaps occur at the junctions of components which can result in potential gas migration pathways. Joints are introduced into the fabric of the building to control thermal movements and differential settlement. Although these joints are often sealed, they are not usually designed or constructed to prevent gas entry. Cracking due to shrinkage and thermal movement following construction can occur in many components used in the construction of buildings. This random cracking is both difficult to predict and to seal retrospectively.

This manual describes and illustrates methods to reduce gas entry through the key ingress routes, thereby reducing the potential for gas to accumulate.

Figure 2.1 Gas entry routes into buildings

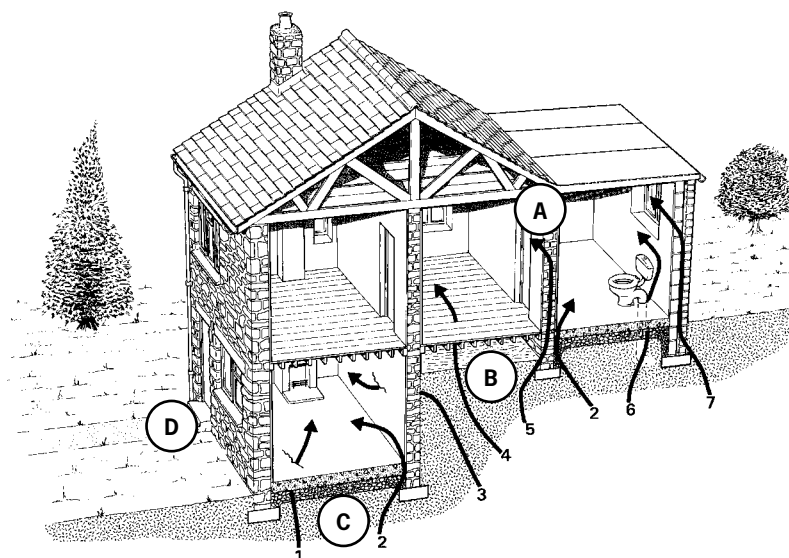

Key to ingress routes:

- 1 Through cracks in solid floors
- 2 Through construction joints
- 3 Through cracks in walls below ground level
- 4 Through gaps in suspended floors
- 5 Through cracks in walls
- 6 Through gaps around service pipes
- 7 Through cavities in walls

Possible locations for gas accumulation:

- A Wall cavities and roof voids
- B Beneath suspended floors
- C Within voids caused by settlement or subsidence
- D Drains and soakaways

Defective construction

Gas entry routes may occur in buildings despite the provision of gas protective measures.

Typical examples of defective construction are:

- Inadequate reinforcement to control cracking in cast-in-place concrete slabs and raft foundations. Where the provision for construction joints is made, they may not be properly sealed.
- The damp-proof course or the damp-proof membrane is lapped but not sealed as it passes through the cavity in a cavity wall. Soil gas from the underlying ground can therefore migrate into the cavity and accumulate there. Shrinkage cracks and partially filled perpend joints can then allow the gas entry into the habitable area of the building.
- The gas-resistant membrane is a critical component in providing protection against soil gas ingress into a building. The membrane can be ruptured easily if it is not laid on a properly prepared formation nor protected from damage from following trades. It is also a common practice for membranes to be lapped but not sealed at the joints: this introduces a gas entry route.
- Gas-resistant membranes laid on poorly compacted fill or highly compressible soils. The membrane may therefore be susceptible to rupture as the fill or soils subsequently settle.
- Service ducts which enter a building through the ground floor slab with gas protective measures are not always properly sealed: this provides a gas entry route into the building. Similarly, with services that enter the building through the external wall at or below ground level, there may be a gas entry route between the outside surface of the service pipe and the wall. Gas entering this way is likely to migrate into the cavity and then into the building.
- Ground-supported cast-in-place concrete slabs constructed upon poorly compacted or unsuitable fill may crack and rupture the gas resistant membrane as it is dressed into the external walls.
- Timber frame construction usually requires the sole-plate or base-plate to be nailed to the external and internal timber frame walls to the top of the ground floor slab. If the gas-resistant membrane is laid on top of the slab, a proprietary sealant tape should be used on top of the gas resistant membrane which self seals the hole formed by the nail. The manufacturer of the proprietary sealant tape should confirm the tape possesses the self-sealing characteristics.

The most common gas entry routes into the building will be reduced significantly if the *Watchpoints* in this manual for each gas protective method are followed.

Abuse of gas protective measures

There are usually no maintenance or control procedures for gas protective measures following occupation of a residential building. The occupier can reduce significantly the effectiveness of the gas protective measures; for example, if the construction of extensions, conservatories and raised patios results in blocked air-bricks that impede air flow through the open void. Abuse of the gas protective measures by the occupier can be reduced if the Health and Safety File references the specific gas protective measures.

2.2 Gas protective measures

In most residential buildings, the primary passive gas protective measures are constructed either at, or just below, the ground floor level. The protection consists of a number of individual elements that combine to form an integrated gas protective system. The type and number of components is a function of the gas protective design. For design guidance, see the Bibliography on page 66.

It is usual practice to utilise for gas protection the components that then serve other purposes, for example the ground floor construction and ventilated open void.

The most commonly used components in a passive gas protective system are:

- ground floor construction;
- gas-resistant membrane;
- open void;
- proprietary void formers;
- granular blanket.

2.2.1 Ground floor construction

A properly constructed ground floor can contribute significantly to the gas protective measures. The most common forms of ground floor construction that can contribute to the gas protective system are:

● Beam-and-block suspended floor supported on loadbearing walls

Beam-and-block floors with screed topping are constructed from purpose made precast concrete beams and concrete blocks. The floor construction is highly permeable with gas entry routes at the joints between the beams and the concrete blocks and especially where blocks are omitted or cut around service entries. The blocks are also highly permeable. However, as the floor does not require to be supported by the ground, the system lends itself to the inclusion of an open void for providing underfloor ventilation.

● **Suspended in-situ concrete slab supported on loadbearing walls**

The ground beneath a suspended in-situ concrete slab is required to act as permanent formwork while the slab cures. After curing, the slab is supported on the perimeter loadbearing walls. Construction joints are best avoided but, if they are necessary, they should be properly formed and sealed.

● **Raft or semi-raft in-situ concrete foundation**

Loose or compressible ground conditions may require the residential building to be built upon a raft or semi-raft foundation. The raft slab may be utilised as a component in the gas protection design. The in-situ concrete slab is usually monolithic and continuous over total ground floor area of the building. With careful detailing of the construction joints, and ensuring there is sufficient reinforcement in the slab to limit cracking, the raft slab is a very effective gas protective measure. The issue with this form of construction is that gas can accumulate beneath the raft slab as it becomes trapped by the edge beam. Incorporating a granular blanket beneath the raft or semi-raft with vent pipes will allow any gas to disperse by passive venting.

2.2.2 Gas resistant membranes

Improved performance of the ground floor to reduce gas ingress can be achieved if a gas-resistant membrane is included. This can be laid either on top of the ground floor or beneath it. There is a wide variation in the permeability characteristics of the proprietary gas-resistant membranes on the market but the usual cause of leakage is that the joints are not adequately sealed or the membrane is damaged during construction.

2.2.3 Open voids

An open void beneath the ground floor with cross-ventilation through the external and internal walls will dilute and disperse the soil gases. To achieve an open void, the floor has to be supported on loadbearing walls. Open voids are restricted to beam-and-block floors or other precast concrete floor systems. To achieve an open void with suspended in-situ concrete floors involves the use of permanent formwork but this is uneconomic for most residential developments.

2.2.4 Proprietary void formers

An alternative to providing ventilation beneath a ground floor slab with an open void is to use proprietary void formers. These are suited to in-situ concrete slabs because they provide permanent formwork as well as a ventilating layer. The void may consist of a geocomposite drainage material or an expanded polystyrene void former.

2.2.5 Granular blankets

A passive venting alternative to the open void and the proprietary void former is the granular blanket but this is less efficient. The granular blanket is constructed beneath, and often provides support to the ground floor slab. There are construction difficulties with this method of providing gas protection. To allow the movement of gas, the granulated blanket should be highly permeable with large particles of crushed rock, concrete or natural aggregate. Unlike a well-graded granular layer, this can be difficult to compact sufficiently to avoid future settlement. Also, the granular blanket can behave like a sump collecting groundwater and thereby lose its ability to perform as a venting medium. Finally, there are practical difficulties with constructing an in-situ concrete slab directly onto the granular blanket. A sand blinding is ineffective if it is laid on the uneven voided blanket material and a substantial thickness of lean mix concrete blinding is required to provide a flat, smooth surface to receive the gas-resistant membrane or the reinforcement.

Guidance on the appropriate specification for the granular blanket is in Section 8.

Further guidance on the efficiency of various underfloor venting systems and their specification is in DETR/Ove Arup Guide for design *Passive venting of soil gases beneath buildings*.

3 New-build floor and sub-structure options

The following details illustrate how passive gas protective measures can be integrated into ground floor and sub-structure construction. The details have been collated from a variety of sources and have been applied to a variety of residential development sites where passive gas protection is required. Since there are many permutations for the arrangement of individual components, the details in this section are not exhaustive.

The construction details generally follow the construction sequence. The watchpoints highlight where particular attention is required to the detail drawings and the on-site construction.

Before specifying or constructing the gas protective measures detailed in this manual, the designer must check they are appropriate for the conditions on the particular site where they are to be used. The designer must also check that there is no conflict between a construction detail to satisfy one criterion (say, gas protection) and another (say, thermal insulation).

Building details that do not relate directly to gas protection have been omitted for reasons of clarity. Therefore, further details will need to be added to satisfy the requirements of the Building Regulations and other design criteria, in particular Building Regulation: Part M: *Accessible thresholds in new housing*.

3.1 Beam-and-block floor with open void

3.1.1 Continuous membrane on top of slab

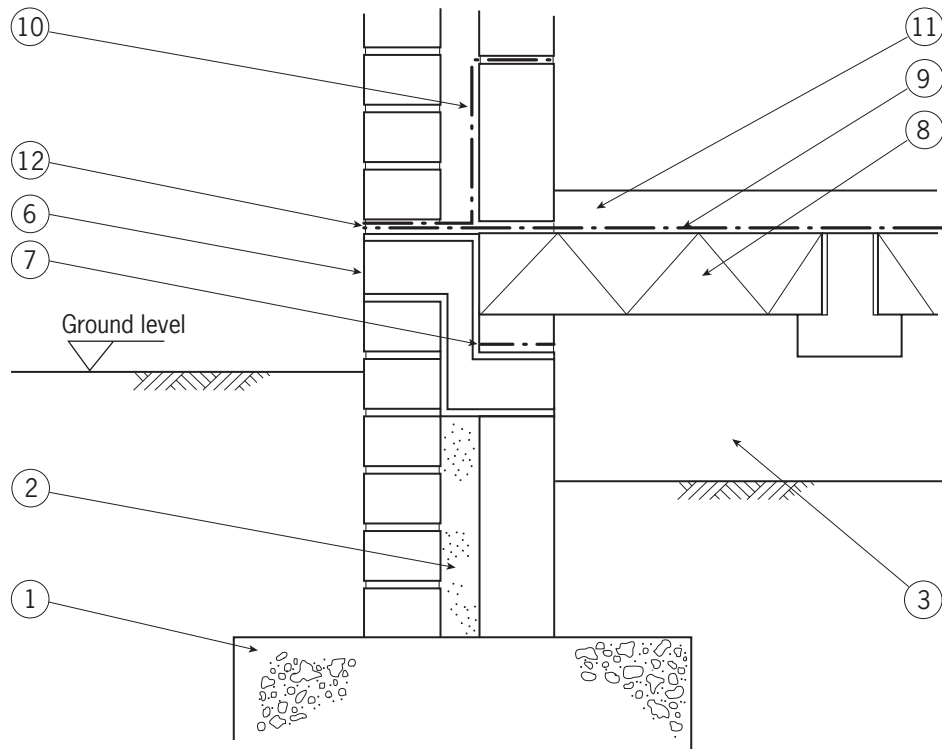

150 mm min

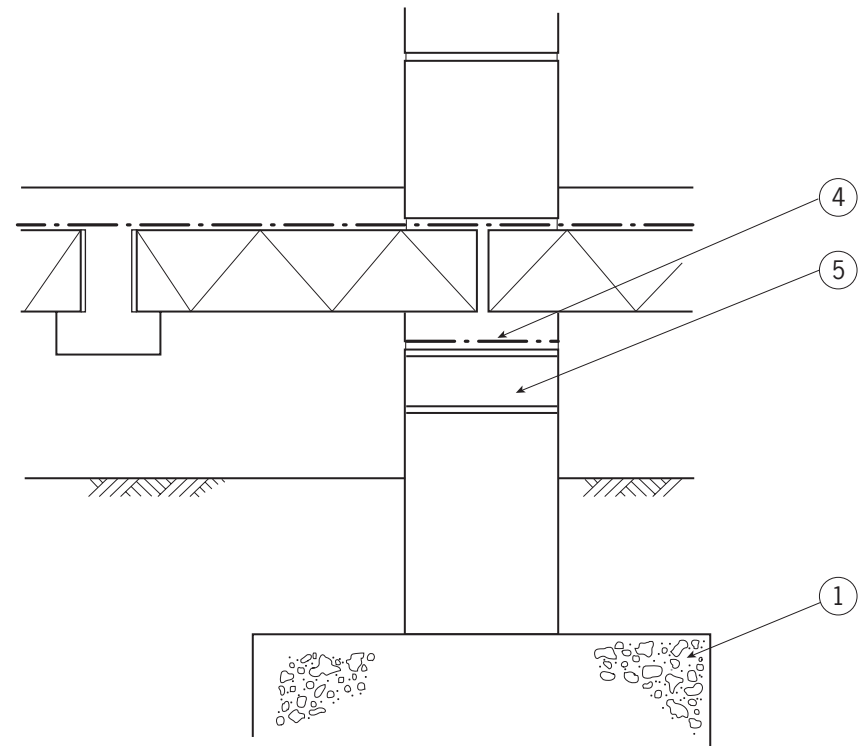

3.1 Beam-and-block floor with open void

3.1.1 Continuous membrane on top of slab

This detail can be adapted to suit access for the disabled, see Section 3.1.2.

See Section 3.4 for membrane and damp-proof course details and Section 6.0 for further information on gas-resistant membranes.

Construction details

- 1 Foundation.
- 2 Concrete cavity fill.
- 3 Open void solum laid to fall and drained.
Ventilation provided with periscope vents and straight-through ventilator.
- 4 Damp-proof course.
- 5 Straight-through ventilator.
- 6 Periscope ventilator.
- 7 Damp-proof course.
- 8 Beam-and-block floor.
- 9 Gas-resistant membrane.
- 10 Cavity tray.
- 11 Screed and insulation.
- 12 Seal (areas of high wind exposure).

Watchpoints

- There should be no movement joints in the substructure masonry below the membrane level and all perpend, gaps and openings should be sealed to avoid gas migration.
- Before laying the membrane, the beam-and-block floor should be thoroughly wetted and all joints grouted with a 4:1 sand:cement grout brushed into all the joints. All projections that may puncture or damage the membrane must be removed. A layer of sacrificial polyethylene could be used.
- If a timber floor is to be constructed over the beam-and-block floor, care is needed to avoid damaging, penetrating or puncturing the slab or gas-resistant membrane.
- Gas membrane should span the cavity and be supported over the cavity with concrete fill or foamed plastics inserts and be continuous across the internal walls.
- Joints in the gas-resistant membrane should be overlapped and taped or site-welded to manufacturer's specifications. If the joints are site-welded, care is needed to avoid damaging the membrane during the welding operation. To avoid the potential for migration pathways from poorly constructed joints, an alternative to site-welding is to install a prefabricated membrane as a single sheet manufactured to the same plan dimensions as the ground floor.
- The gas-resistant membrane should be protected until the screed is laid, for example with boarding. Any damage to the membrane should be made good after the removal of the protection and before laying the screed.
- The gas-resistant membrane material where used as a damp-proof course must comply with the relevant British Standards or British Board of Agreement (BBA) certificate for damp-proof courses.
- The base of the solum should be not lower than the external ground level if there is the risk of water collecting in the solum because the soil is not free-draining or there is a high groundwater level.
- To avoid waterlogging/ponding, membranes should not be laid in the base of the solum.
- Care should be taken to ensure the gas-resistant membrane and damp-proof course is continuous around door openings.
- Soil gas can accumulate in service trenches and manholes so where these form a gas migration pathway, they should be sealed with a gas-tight seal. CIRIA Report 149 *Protecting development from methane* describes methods of sealing service trenches and manholes.

3.1 Beam-and-block floor with open void
3.1.2 Access for the disabled – threshold detail

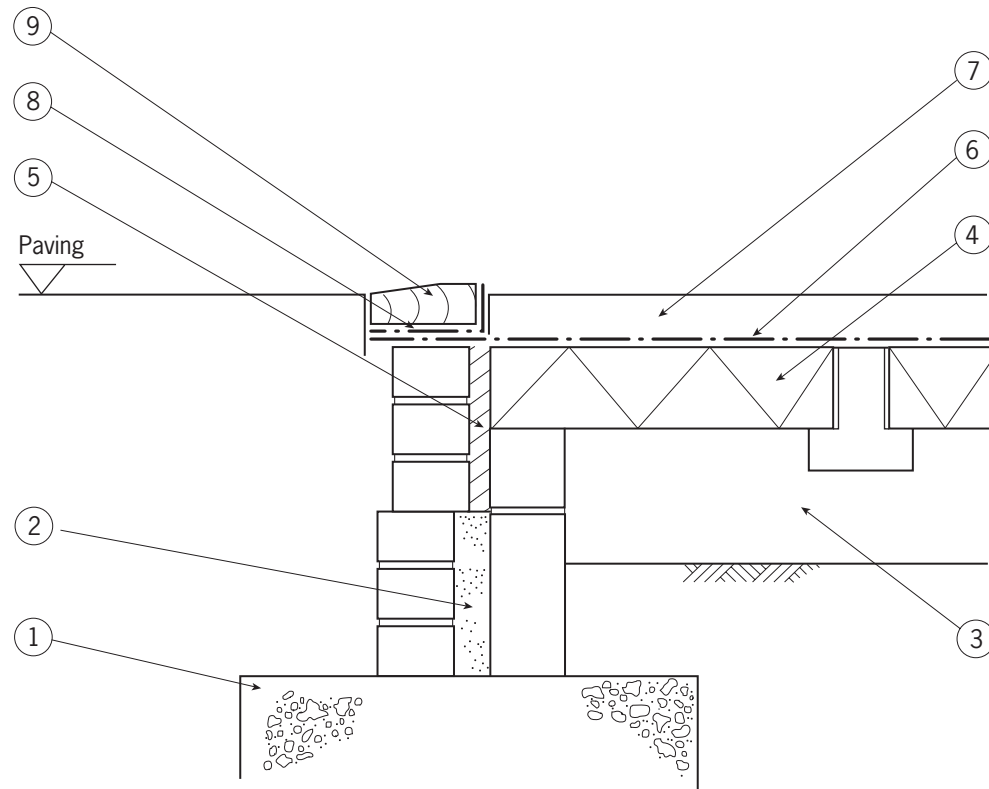

3.1 Beam-and-block floor with open void

3.1.2 Access for the disabled – threshold detail

See Section 3.4 for membrane and damp-proof course details and Section 6.0 for further information on gas-resistant membranes.

Construction details

- 1 Foundation.
- 2 Concrete cavity fill.
- 3 Open void solum laid to fall and drained.
Ventilation is provided with periscope vents either side of threshold where external ground is at a reduced level, and straight-through ventilators at internal walls.
- 4 Beam-and-block floor.
- 5 Polyfoam cavity fill or similar.
- 6 Gas-resistant membrane.
- 7 Screed and insulation.
- 8 Gas-resistant damp-proof course.
- 9 Sill.

Watchpoints

- There should be no movement joints in the substructure masonry below the membrane level and all perpend, gaps and openings should be sealed to avoid gas migration.
- Before laying the membrane, the beam-and-block floor should be thoroughly wetted and all joints grouted with a 4:1 sand:cement grout brushed into all the joints. All projections that may puncture or damage the membrane must be removed. A layer of sacrificial polyethylene could be used.
- If a timber floor is to be constructed over the beam-and-block floor, care is needed to avoid damaging, penetrating or puncturing the slab or gas-resistant membrane.
- Gas membrane should span the cavity and be supported over the cavity with concrete fill or foamed plastics inserts and be continuous across the internal walls.
- Joints in the gas-resistant membrane should be overlapped and taped or site-welded to manufacturer's specifications. If the joints are site-welded, care is needed to avoid damaging the membrane during the welding operation. To avoid the potential for migration pathways from poorly constructed joints, an alternative to site-welding is to install a prefabricated membrane as a single sheet manufactured to the same plan dimensions as the ground floor.
- The gas-resistant membrane should be protected until the screed is laid, for example with boarding. Any damage to the membrane should be made good after the removal of the protection and before laying the screed.
- The gas-resistant membrane material where used as a damp-proof course must comply with the relevant British Standards or British Board of Agreement (BBA) certificate for damp-proof courses.
- The base of the solum should be not lower than the external ground level if there is the risk of water collecting in the solum because the soil is not free-draining or there is a high ground water level.
- To avoid waterlogging/ponding, membranes should not be laid in the base of the solum.
- Care is needed to ensure the gas-resistant membrane and damp-proof course is continuous around door openings.
- Soil gas can accumulate in service trenches and manholes so where these form a gas migration pathway, they should be sealed with a gas-tight seal. CIRIA Report 149 *Protecting development from methane* describes methods of sealing service trenches and manholes.
- Adequate drainage may be required between the paving and the sill.

3.1 Beam-and-block floor with open void
3.1.3 Stepped membrane at external wall

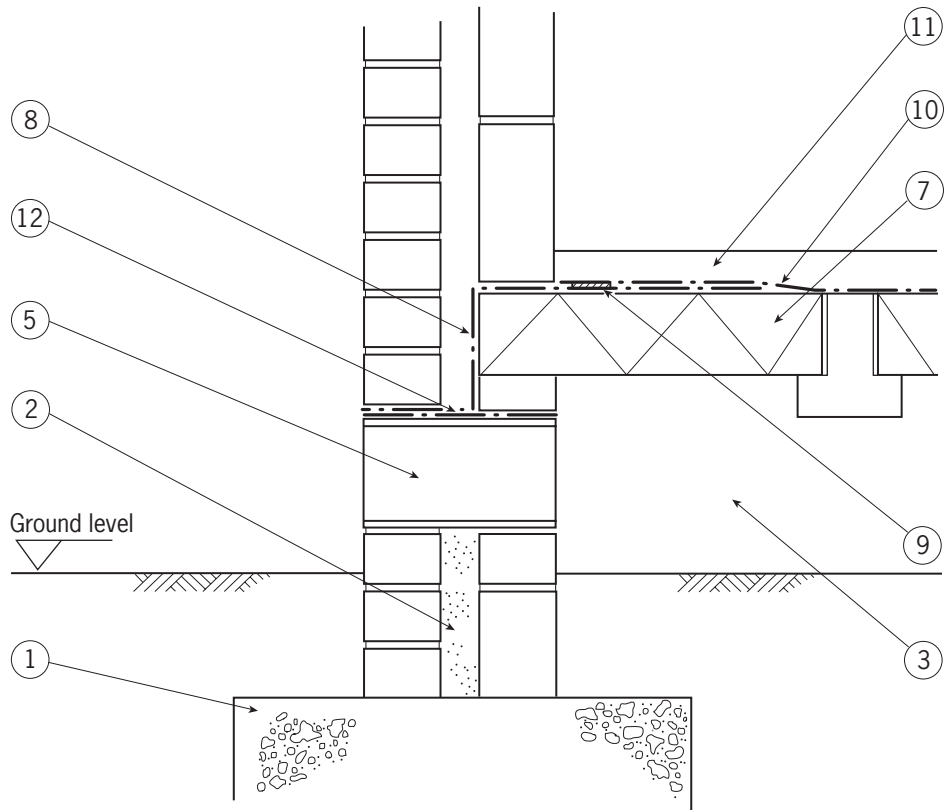

150 mm min

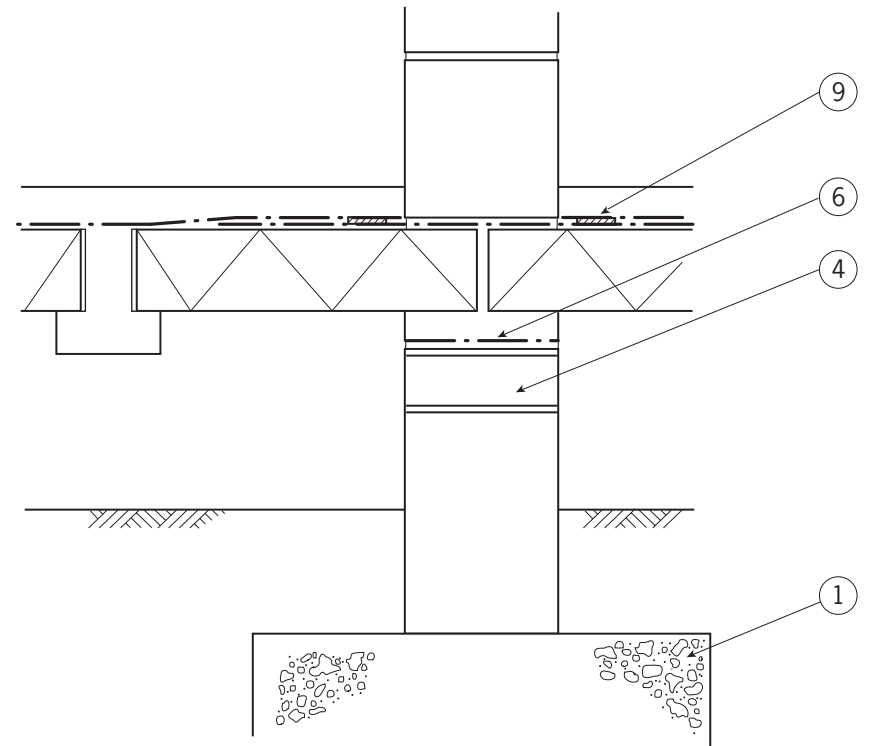

3.1 Beam-and-block floor with open void

3.1.3 Stepped membrane at external wall

See Section 3.4 for membrane and damp-proof course details and Section 6.0 for further information on gas-resistant membranes.

Construction details

- 1 Foundation.
- 2 Concrete cavity fill.
- 3 Open void solum laid to fall and drained.
- 4 Straight-through ventilator.
- 5 Air-brick.
- 6 Damp-proof course.
- 7 Beam-and-block floor.
- 8 Gas-resistant damp-proof course/gas-resistant proprietary cavity tray.
- 9 50 mm double-sided tape or butyl bonded strips.
- 10 Gas-resistant membrane.
- 11 Screed and insulation.
- 12 Gas-resistant damp-proof course.

Watchpoints

- There should be no movement joints in the substructure masonry below the membrane level and all perpend, gaps and openings should be sealed to avoid gas migration.
- Before laying the membrane, the beam-and-block floor should be thoroughly wetted and all joints grouted with a 4:1 sand:cement grout brushed into all the joints. All projections that may puncture or damage the membrane are removed. A layer of sacrificial polyethylene could be used.
- If a timber floor is to be constructed over the beam-and-block floor, care is needed to avoid damaging, penetrating or puncturing the slab or gas-resistant membrane.

- The gas-resistant membrane should be protected until the screed is laid, for example with boarding. Any damage to the membrane should be made good after the removal of the protection and before laying the screed.
- Damage to the gas-resistant membrane may be minimised if the membrane is laid during two separate visits to site. The section of the membrane dressed into the walls is laid on the first visit and the section within the floor area laid subsequently.
- The base of the solum should not be lower than the external ground level if there is the risk of water collecting in the solum because the soil is not free-draining or there is a high groundwater level.
- A proprietary gas-resistant damp-proof course/gas-resistant proprietary cavity tray should be used at corners and changes in levels. Pre-formed proprietary products are preferred to in-situ methods.
- Joints in the gas-resistant membrane should be overlapped and taped or site-welded to manufacturer's specifications. If the joints are site-welded, care is needed to avoid damaging the membrane during the welding operation. To avoid the potential for migration pathways from poorly constructed joints, an alternative to site-welding is to install a prefabricated membrane as a single sheet manufactured to the same plan dimensions as the ground floor.
- To avoid waterlogging/ponding, membranes should not be laid in the base of the solum.
- The lap between the proprietary gas-resistant damp-proof course and the gas-resistant proprietary cavity tray should be sealed throughout its length with gas-resistant tape.
- The gas-resistant membrane material where used as a damp-proof course must comply with the relevant British Standards or British Board of Agreement (BBA) certificate for damp-proof courses.
- Soil gas can accumulate in service trenches and manholes so where these form a gas migration pathway, they should be sealed as a gas-tight seal. CIRIA Report 149 *Protecting development from methane* describes methods of sealing service trenches and manholes.
- Care is needed to ensure the gas-resistant membrane and damp-proof course is continuous around door openings.

3.2 Suspended in-situ concrete slab with void former

3.2.1 Continuous membrane on top of slab with slab constructed on a geocomposite drainage blanket or expanded polystyrene void former

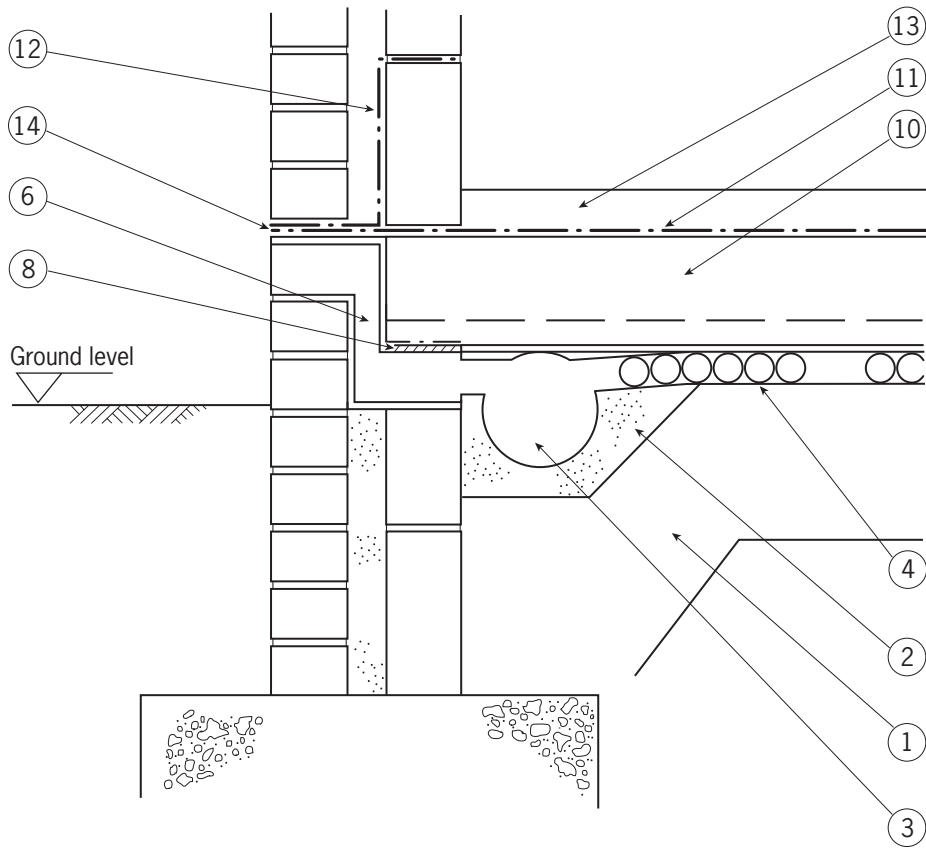

Slab with geocomposite drainage blanket

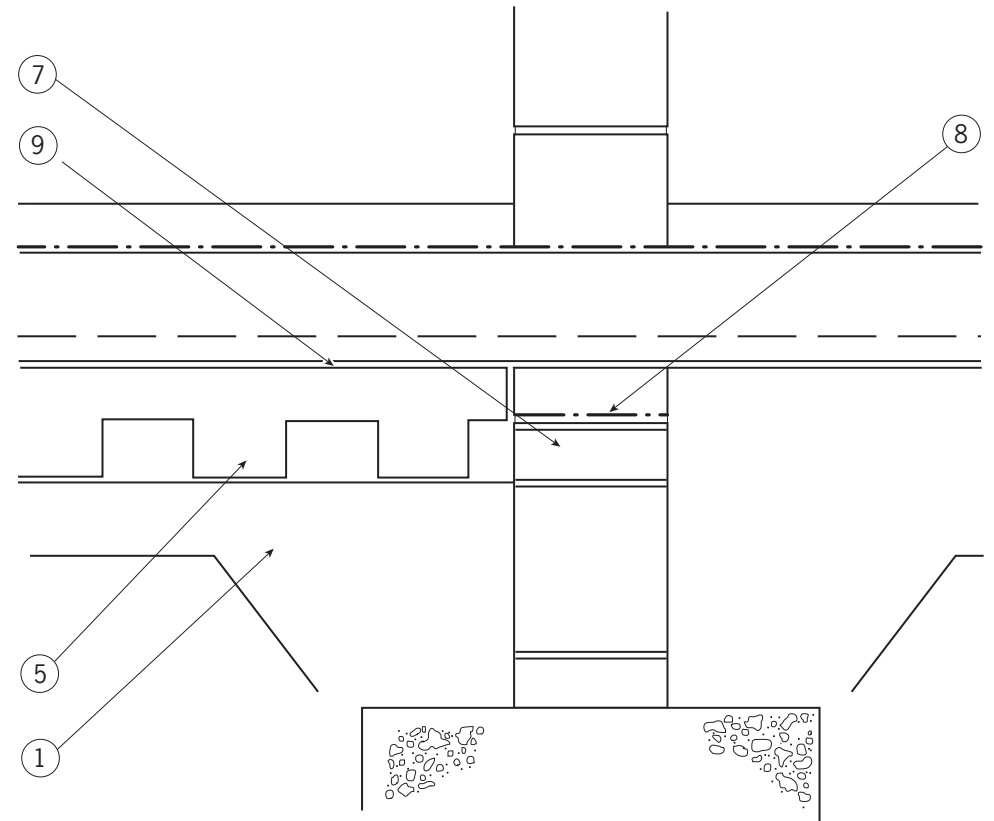

Slab with expanded polystyrene void former

3.2 Suspended in-situ concrete slab with void former

3.2.1 Continuous membrane on top of slab with slab constructed on a geocomposite drainage blanket or expanded polystyrene void former

This detail can be adapted to suit access for the disabled, see Section 3.1.2.

See Section 3.4 for membrane and damp-proof course details and Section 6.0 for further information on gas-resistant membranes.

Construction details

- 1 Well-graded inert fill mechanically compacted in layers not exceeding 225 mm thick.
- 2 Mortar bed and surround.
- 3 Perimeter gas collection pipe connected to geocomposite drainage blanket and periscope and straight-through ventilator.
- 4 Proprietary geocomposite drainage blanket.
- 5 Proprietary expanded polystyrene void former.
- 6 Periscope ventilator.
- 7 Straight-through ventilator.
- 8 Damp-proof course.
- 9 Grout check membrane (required only for proprietary expanded polystyrene void former).
- 10 In-situ reinforced concrete suspended slab.
- 11 Gas-resistant membrane.
- 12 Cavity tray.
- 13 Screed and insulation.
- 14 Seal (areas of high wind exposure).

Watchpoints

- There should be no movement joints in the substructure masonry below the membrane level and all perpend, gaps and openings should be sealed to avoid gas migration.
- If a timber floor is to be constructed over the in-situ concrete slab, care is needed to avoid damaging, penetrating or puncturing the slab or gas-resistant membrane.
- Before laying the membrane all projections on the top of the slab which may puncture or damage the membrane must be removed. A layer of sacrificial polyethylene could be used.
- Gas membrane should span the cavity and be supported over the cavity with concrete fill or foamed plastics inserts and be continuous across the internal walls.
- Joints in the gas-resistant membrane should be overlapped and taped or site-welded to manufacturer's specifications. If the joints are site-welded, care is needed to avoid damaging the membrane during the welding operation. To avoid the potential for migration pathways poorly constructed joints, an alternative to site-welding is to install a prefabricated membrane as a single sheet manufactured to the same plan dimensions as the ground floor.
- The gas-resistant membrane should be protected until the screed is laid, for example with boarding. Any damage to the membrane should be made good after the removal of the protection and before laying the screed.
- The gas-resistant membrane material where used as a damp-proof course must comply with the relevant British Standards or British Board of Agreement (BBA) certificate for damp-proof courses.
- Soil gas can accumulate in service trenches and manholes so where these form a gas migration pathway, they should be sealed as a gas-tight seal. CIRIA Report 149 *Protecting development from methane* describes methods of sealing service trenches and manholes.
- Polystyrene used in construction can be obtained in a variety of grades. The correct grade polystyrene must be used for gas-contaminated sites in accordance with the manufacturer's recommendations.
- Care is needed to ensure the gas-resistant membrane and damp-proof course is continuous around door openings.

3.2 Suspended in-situ concrete slab with void former

3.2.2 Access for the disabled – threshold detail

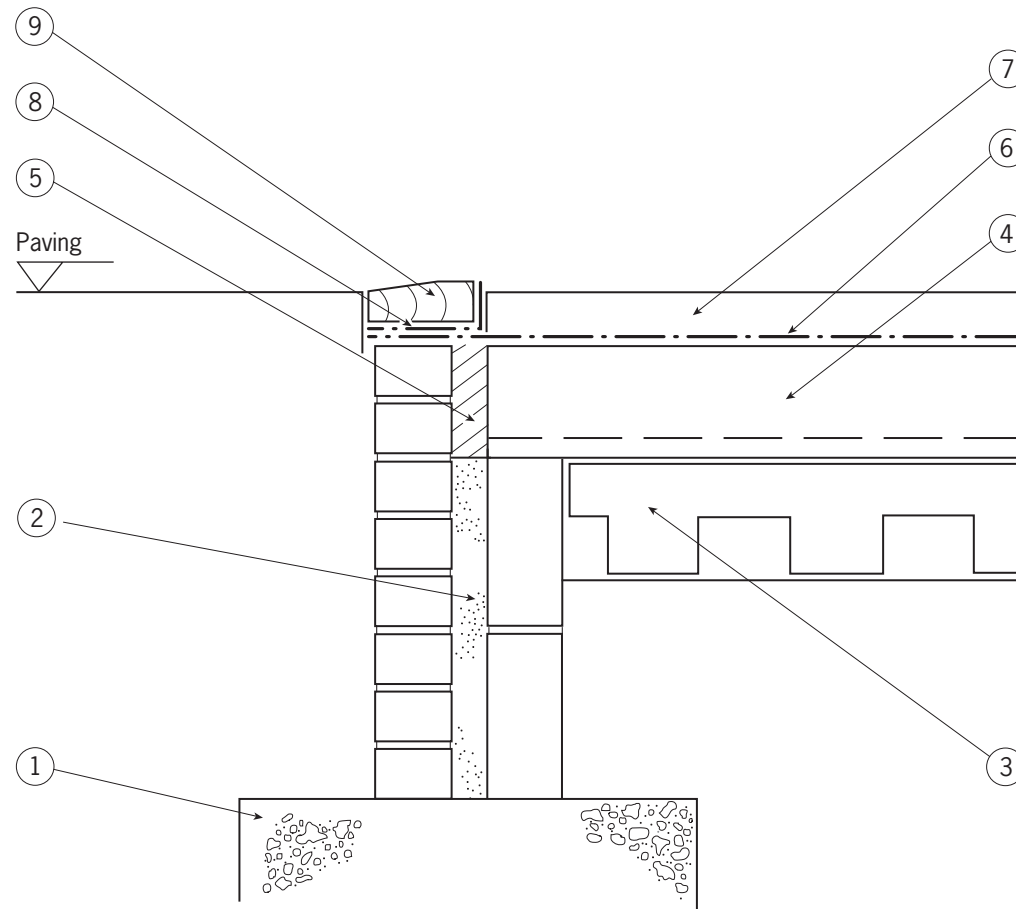

3.2 Suspended in-situ concrete slab with void former

3.2.2 Access for the disabled – threshold detail

See Section 3.4 for membrane and damp-proof course details and Section 6.0 for further information on gas-resistant membranes.

Construction details

- 1 Foundation.
- 2 Concrete cavity fill.
- 3 Proprietary void former – see Section 3.2.1.
- 4 In-situ reinforced concrete suspended slab.
- 5 Polyfoam cavity fill or similar.
- 6 Gas-resistant membrane.
- 7 Screed and insulation.
- 8 Damp-proof course.
- 9 Sill.

Watchpoints

- There should be no movement joints in the substructure masonry below the membrane level and all perpend, gaps and openings should be sealed to avoid gas migration.
- If a timber floor is to be constructed over the in-situ concrete slab, care is needed to avoid damaging, penetrating or puncturing the slab or gas-resistant membrane.
- Before laying the membrane all projections on the top of the slab which may puncture or damage the membrane must be removed. A layer of sacrificial polyethylene could be used.
- Gas membrane should span the cavity and be continuous across the internal walls.
- Joints in the gas-resistant membrane should be overlapped and taped or site-welded to manufacturer's specifications. If the joints are site-welded, care should be taken to avoid damaging the membrane during the welding operation. To avoid the potential for migration pathways from poorly constructed joints, an alternative to site-welding is to install a prefabricated membrane as a single sheet manufactured to the same plan dimensions as the ground floor.
- The gas-resistant membrane should be protected until the screed is laid, for example with boarding. Any damage to the membrane should be made good after the removal of the protection and before laying the screed.
- The gas-resistant membrane material where used as a damp-proof course must comply with the relevant British Standards or British Board of Agreement (BBA) certificate for damp-proof courses.
- Soil gas can accumulate in service trenches and manholes so where these form a gas migration pathway, they should be sealed as a gas-tight seal. CIRIA Report 149 *Protecting development from methane* describes methods of sealing service trenches and manholes.
- Polystyrene used in construction can be obtained in a variety of grades. The correct grade polystyrene must be used for gas-contaminated sites in accordance with the manufacturer's recommendations.
- Care is needed to ensure the gas-resistant membrane and damp-proof course is continuous around door openings.
- Adequate drainage may be required between the paving and the sill.

3.3 Raft or semi-raft foundation

3.3.1.1 Membrane on top of slab – external wall

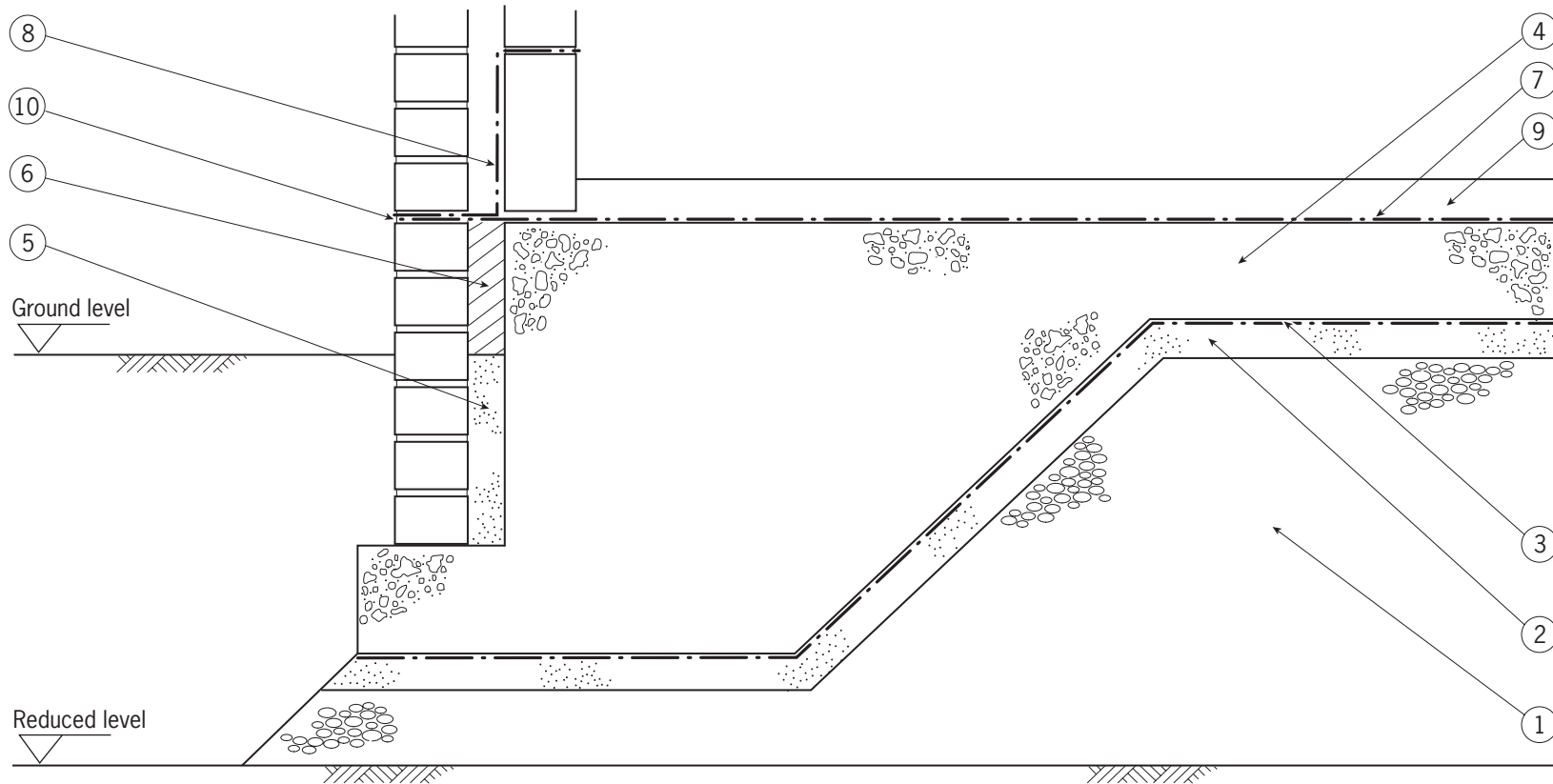

3.3 Raft or semi-raft foundation

3.3.1.1 Membrane on top of slab – external wall

This detail omits a ventilation layer beneath the slab.

To limit the potential for gas to accumulate beneath the slab, this detail is applicable only with raft or semi-raft foundations with a plan area of less than 10 m².

Construction details

- 1 Well-graded inert fill mechanically compacted in layers not exceeding 225 mm thick.
- 2 50 mm sand blinding or lean mix concrete blinding.
- 3 Grout check membrane.
- 4 Reinforced concrete raft or semi-raft foundation.
- 5 Concrete cavity fill.
- 6 Polyfoam cavity fill or similar to support membrane.
- 7 Gas-resistant membrane.
- 8 Cavity tray.
- 9 Screed and insulation.
- 10 Seal (areas of high wind exposure).

Watchpoints

- ❑ The inert fill should be selected, laid and compacted to minimise air voids.
- ❑ The reinforced concrete raft or semi-raft foundation should be designed, detailed and constructed to accord with BS 8110: Part 1. Sufficient reinforcement should be included to control cracking. The concrete should be mechanically vibrated.
- ❑ Construction or movement joints in the raft or semi-raft should be avoided if possible. If joints are necessary, they should be detailed by the designer and their location indicated on the detailed drawings. The joints should be positioned to avoid creating a gas migration pathway into the building. A water bar incorporated in the joint should be considered.
- ❑ There should be no movement joints in the substructure masonry below the membrane level and all perpend, gaps and openings should be sealed to avoid gas migration.
- ❑ If a timber floor is to be constructed over the in-situ concrete slab, care should be taken to avoid damaging, penetrating or puncturing the slab or gas-resistant membrane.
- ❑ Before laying the membrane all projections on the top of the slab which may puncture or damage the membrane must be removed. A layer of sacrificial polyethylene could be used.
- ❑ Gas membrane should span the cavity and be supported over the cavity with concrete fill or foamed plastics inserts and be continuous across the internal walls.
- ❑ Joints in the gas-resistant membrane should be overlapped and taped or site-welded to manufacturer's specifications. If the joints are site-welded, care is needed to avoid damaging the membrane during the welding operation. To avoid the potential for migration pathways that may arise from poorly constructed joints, an alternative to site-welding is to install a prefabricated membrane as a single sheet manufactured to the same plan dimensions as the ground floor.
- ❑ The gas-resistant membrane should be protected until the screed is laid, for example with boarding. Any damage to the membrane should be made good after the removal of the protection and before laying the screed.
- ❑ The gas-resistant membrane material where used as a damp-proof course must comply with the relevant British Standards or British Board of Agreement (BBA) certificate for damp-proof courses.
- ❑ Soil gas can accumulate in service trenches and manholes so where these form a gas migration pathway, they should be sealed as a gas-tight seal. CIRIA Report 149 *Protecting development from methane* describes methods of sealing service trenches and manholes.

3.3 Raft or semi-raft foundation

3.3.1.2 Membrane on top of slab – internal wall

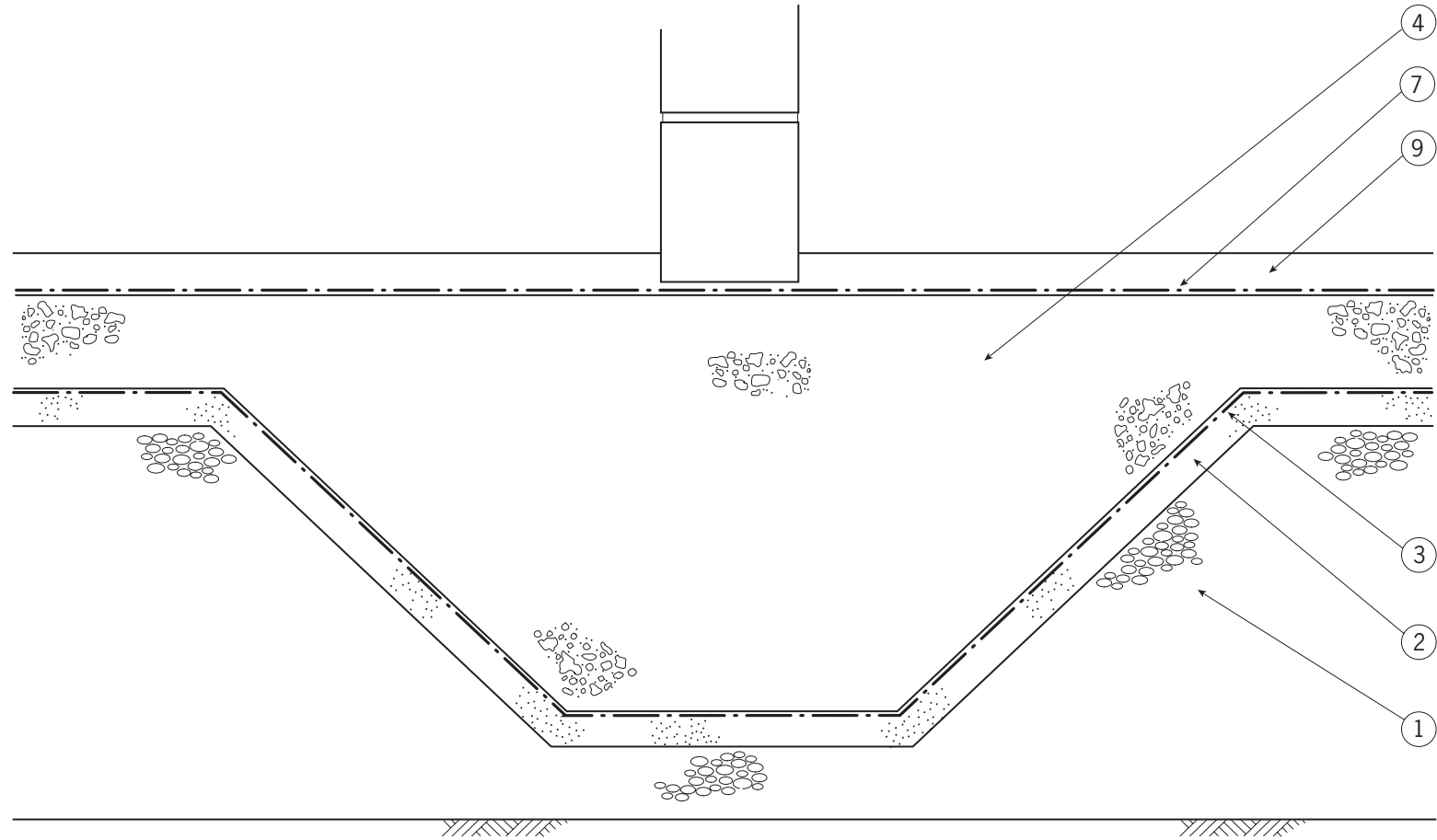

3.3 Raft or semi-raft foundation

3.3.1.2 Membrane on top of slab – internal wall

This detail omits a ventilation layer beneath the slab.

To limit the potential for gas to accumulate beneath the slab, this detail is applicable only with raft or semi-raft foundations with a plan area of less than 10 m².

Construction details

- 1 Well-graded inert fill mechanically compacted in layers not exceeding 225 mm thick.
- 2 50 mm sand blinding or lean mix concrete blinding.
- 3 Grout check membrane.
- 4 Reinforced concrete raft or semi-raft foundation.
- 7 Gas-resistant membrane.
- 9 Screed and insulation.

Watchpoints

- ❑ The inert fill should be selected, laid and compacted to minimise air voids.
- ❑ The reinforced concrete raft or semi-raft foundation should be designed, detailed and constructed to accord with BS 8110: Part 1. Sufficient reinforcement should be included to control cracking. The concrete should be mechanically vibrated.
- ❑ Construction or movement joints in the raft or semi-raft should be avoided if possible. If joints are necessary, they should be detailed by the designer and their location indicated on the detailed drawings. The joints should be positioned to avoid creating a gas migration pathway into the building. A water bar incorporated in the joint should be considered.
- ❑ There should be no movement joints in the substructure masonry below the membrane level and all perpend, gaps and openings should be sealed to avoid gas migration.
- ❑ If a timber floor is to be constructed over the in-situ concrete slab, care should be taken to avoid damaging, penetrating or puncturing the slab or gas-resistant membrane.
- ❑ Before laying the membrane all projections on the top of the slab which may puncture or damage the membrane must be removed. A layer of sacrificial polyethylene could be used.
- ❑ Gas membrane should span the cavity and be supported over the cavity with concrete fill or foamed plastics inserts and be continuous across the internal walls.
- ❑ Joints in the gas-resistant membrane should be overlapped and taped or site-welded to manufacturer's specifications. If the joints are site-welded, care is needed to avoid damaging the membrane during the welding operation. To avoid the potential for migration pathways that may arise from poorly constructed joints, an alternative to site-welding is to install a prefabricated membrane as a single sheet manufactured to the same plan dimensions as the ground floor.
- ❑ The gas-resistant membrane should be protected until the screed is laid, for example with boarding. Any damage to the membrane should be made good after the removal of the protection and before laying the screed.
- ❑ The gas-resistant membrane material where used as a damp-proof course must comply with the relevant British Standards or British Board of Agreement (BBA) certificate for damp-proof courses.
- ❑ Soil gas can accumulate in service trenches and manholes so where these form a gas migration pathway, they should be sealed as a gas-tight seal. CIRIA Report 149 *Protecting development from methane* describes methods of sealing service trenches and manholes.

3.3 Raft or semi-raft foundation

3.3.2.1 Membrane on top of slab with below slab ventilation layer – external wall

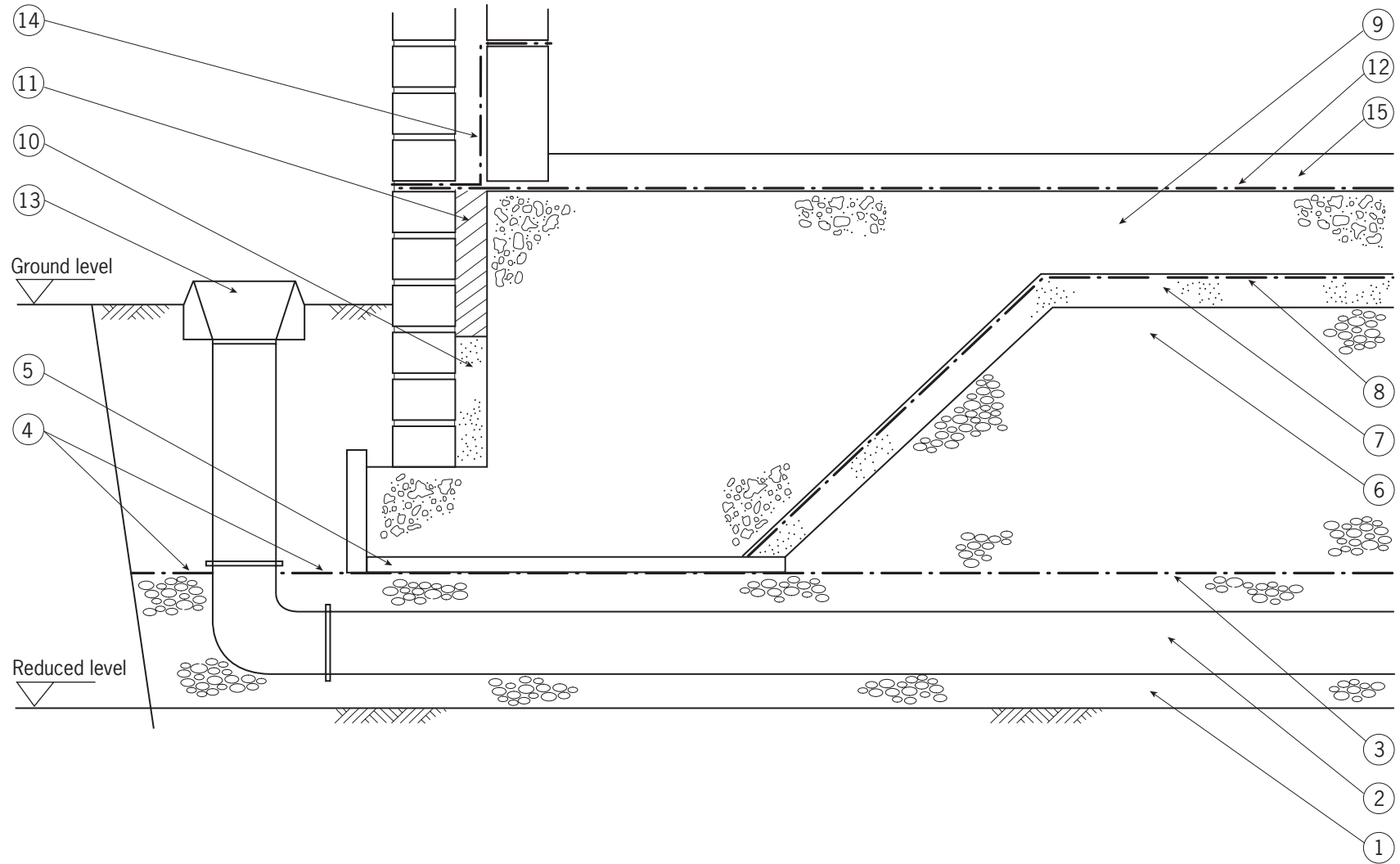

3.3 Raft or semi-raft foundation

3.3.2.1 Membrane on top of slab with below slab ventilation layer – external wall

Construction details

- 1 Granular blanket – see Section 8.
- 2 Slotted gas collection pipe – see Section 9.
- 3 Geotextile.
- 4 Gas-resistant membrane.
- 5 Lean mix concrete blinding with stop end shutter.
- 6 Well-graded inert fill mechanically compacted in layers not exceeding 225 mm thick.
- 7 50 mm sand blinding or lean mix concrete blinding.
- 8 Grout check membrane.
- 9 Reinforced concrete raft or semi-raft foundation.
- 10 Concrete cavity fill.
- 11 Polyfoam cavity fill or similar to support membrane
- 12 Gas-resistant membrane.
- 13 Plain pipe with ground level vent or eaves level vertical riser.
- 14 Cavity tray.
- 15 Screed and insulation.

Watchpoints

- ❑ The use of the granular blanket should be restricted to sites with a low groundwater level and the underlying soils are high permeability and free-draining. The granular blanket can be difficult to compact.
- ❑ The inert fill should be selected, laid and compacted to minimise air voids.
- ❑ The reinforced concrete raft or semi-raft foundation should be designed, detailed and constructed to accord with BS 8110: Part 1. Sufficient reinforcement should be included to control cracking. The concrete should be mechanically vibrated.

- ❑ Construction or movement joints in the raft or semi-raft should be avoided if possible. If joints are necessary, they should be detailed by the designer and their location indicated on the detailed drawings. The joints should be positioned to avoid creating a gas migration pathway into the building. A proprietary water bar incorporated in the joint with sealant is essential.
- ❑ There should be no movement joints in the substructure masonry below the membrane level and all perpend, gaps and openings should be sealed to avoid gas migration.
- ❑ If a timber floor is to be constructed over the in-situ concrete slab, care should be taken to avoid damaging, penetrating or puncturing the slab or gas-resistant membrane.
- ❑ Before laying the membrane all projections on the top of the slab which may puncture or damage the membrane must be removed. A layer of sacrificial polyethylene could be used.
- ❑ The ground level vent should not discharge close to windows, doors or other openings in the external envelope of the building. Ground-level vents are susceptible to becoming blocked with leaves and snow. An alternative to the ground-level vent is to use an eaves-level vertical riser – see Section 3.3.2.2.
- ❑ The vertical riser should discharge above eaves level and not adjacent to windows, rooflights or roof-level air intake or vents and other openings in the external envelope of the building – see Section 7.3.

- ❑ Gas membrane should span the cavity and be supported over the cavity with concrete fill or foamed plastics inserts and be continuous across internal walls.
- ❑ Joints in the gas-resistant membrane should be overlapped and taped or site-welded to manufacturer's specifications. If the joints are site-welded, care should be taken to avoid damaging the membrane during the welding operation. To avoid the potential for migration pathways that may arise from poorly constructed joints, an alternative to site-welding is to install a prefabricated membrane as a single sheet manufactured to the same plan dimensions as the ground floor.
- ❑ The gas-resistant membrane should be protected until the screed is laid, eg with boarding. Any damage to the membrane should be made good after the removal of the protection and before laying the screed.
- ❑ The gas-resistant membrane material where used as a damp-proof course must comply with the relevant British Standards or British Board of Agreement (BBA) certificate for damp-proof courses.
- ❑ Soil gas can accumulate in service trenches and manholes so where these form a gas migration pathway, they should be sealed as a gas-tight seal. CIRIA Report 149 *Protecting development from methane* describes methods of sealing service trenches and manholes.

3.3 Raft or semi-raft foundation

3.3.2.2 Membrane on top of slab with below slab ventilation layer – external wall – alternative detail with vertical riser

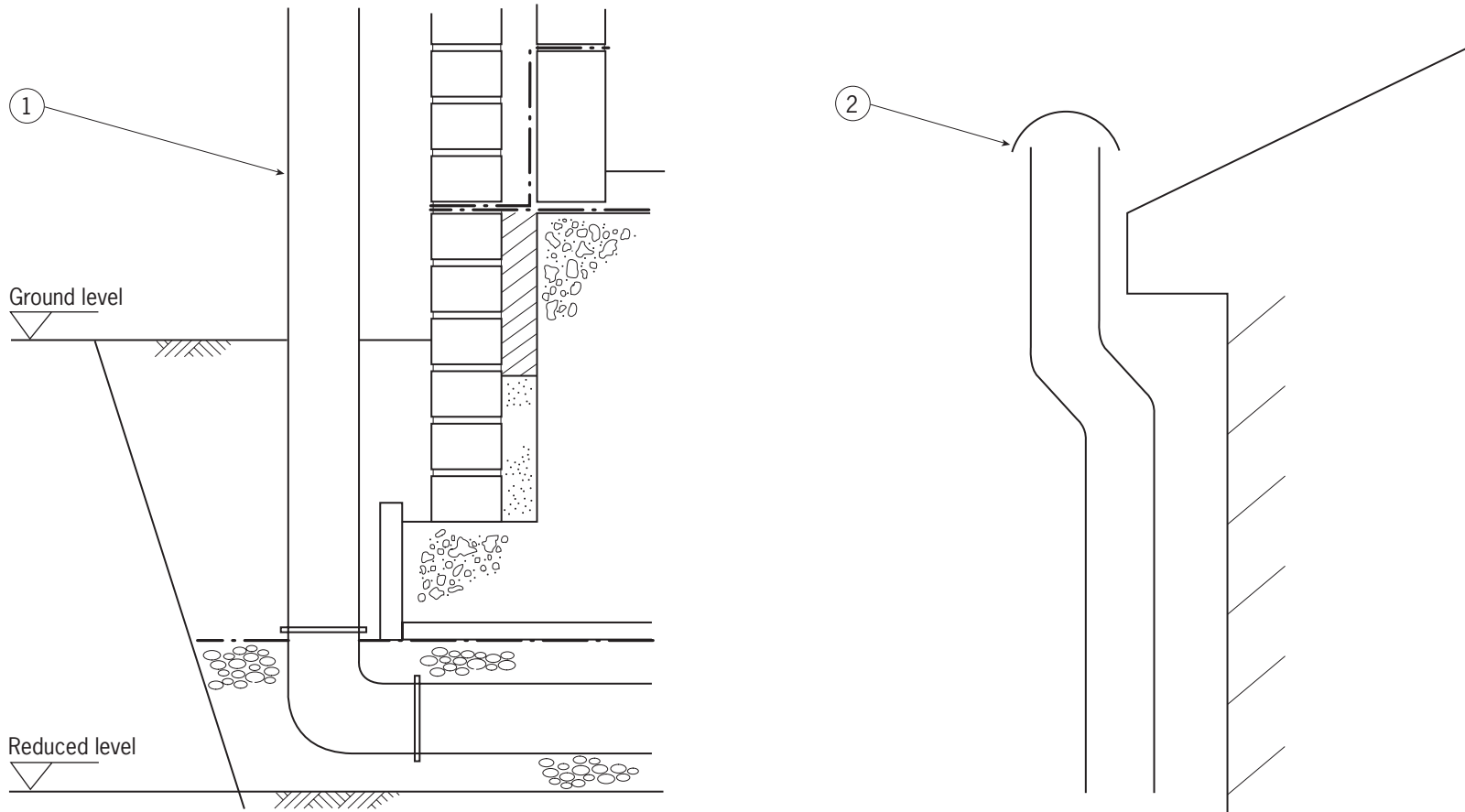

3.3 Raft or semi-raft foundation

3.3.2.2 Membrane on top of slab with below slab ventilation layer – external wall – alternative detail with vertical riser

Construction details

- 1** Plain pipe with ground level vent or eaves level vertical riser.
- 2** Vent cowl – see Section 7.3.

Watchpoints

- The vertical riser should discharge above eaves level and not adjacent to windows, rooflights or roof-level air intake or vents and other openings in the external envelope of the building – see Section 7.3.
- If possible, riser should be free of joints from ground to eaves.

3.3 Raft or semi-raft foundation

3.3.2.3 Membrane on top of slab with below slab ventilation layer – internal wall

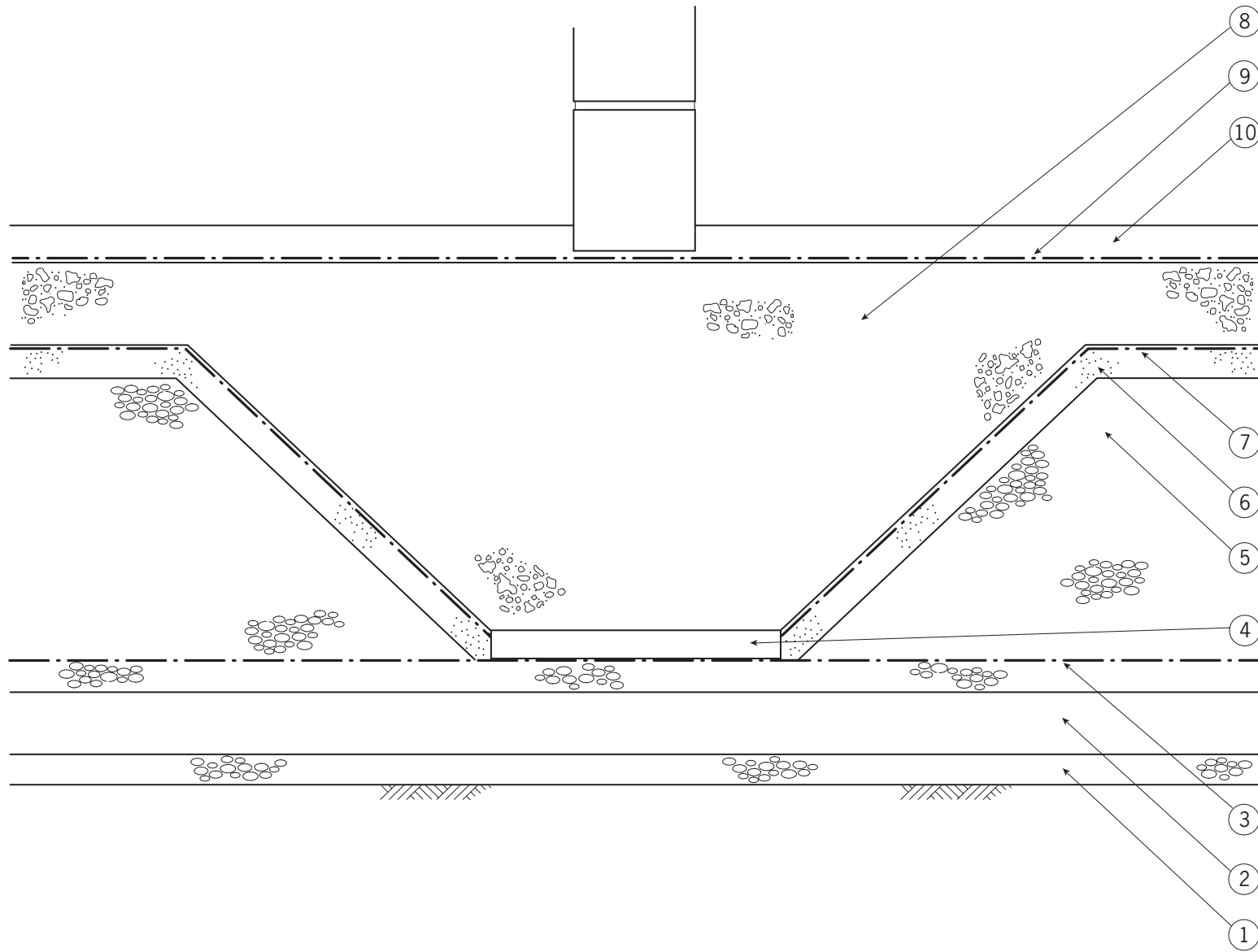

3.3 Raft or semi-raft foundation

3.3.2.3 Membrane on top of slab with below slab ventilation layer – internal wall

Construction details

- 1 Granular blanket – see Section 8.
- 2 Slotted gas collection pipe – see Section 9.
- 3 Geotextile.
- 4 Lean mix concrete blinding with stop end shutter.
- 5 Well-graded inert fill mechanically compacted in layers not exceeding 225 mm thick.
- 6 50 mm sand blinding or lean mix concrete blinding.
- 7 Grout check membrane.
- 8 Reinforced concrete raft or semi-raft foundation.
- 9 Gas-resistant membrane.
- 10 Screed and insulation.

Watchpoints

- ❑ The use of the granular blanket should be restricted to sites with a low groundwater level and the underlying soils are high permeability and free-draining. The granular blanket can be difficult to compact.
- ❑ The inert fill should be selected, laid and compacted to minimise air voids.
- ❑ The reinforced concrete raft or semi-raft foundation should be designed, detailed and constructed to accord with BS 8110: Part 1. Sufficient reinforcement should be included to control cracking. The concrete should be mechanically vibrated.
- ❑ Construction or movement joints in the raft or semi-raft should be avoided if possible. If joints are necessary, they should be detailed by the designer and their location indicated on the detailed drawings. The joints should be positioned to avoid creating a gas migration pathway into the building. A proprietary water bar incorporated in the joint with sealant is essential.
- ❑ There should be no movement joints in the substructure masonry below the membrane level and all perpend, gaps and openings should be sealed to avoid gas migration.
- ❑ If a timber floor is to be constructed over the in-situ concrete slab, care should be taken to avoid damaging, penetrating or puncturing the slab or gas-resistant membrane.
- ❑ Gas membrane should span the cavity and be supported over the cavity with concrete fill or foamed plastics inserts and be continuous across internal walls.
- ❑ Before laying the membrane all projections on the top of the slab which may puncture or damage the membrane must be removed. A layer of sacrificial polyethylene could be used.
- ❑ Joints in the gas-resistant membrane should be overlapped and taped or site-welded to manufacturer's specifications. If the joints are site-welded, care should be taken to avoid damaging the membrane during the welding operation. To avoid the potential for migration pathways that may arise from poorly constructed joints, an alternative to site-welding is to install a prefabricated membrane as a single sheet manufactured to the same plan dimensions as the ground floor.
- ❑ The gas-resistant membrane should be protected until the screed is laid, eg with boarding. Any damage to the membrane should be made good after the removal of the protection and before laying the screed.
- ❑ The gas-resistant membrane material where used as a damp-proof course must comply with the relevant British Standards or British Board of Agreement (BBA) certificate for damp-proof courses.
- ❑ Soil gas can accumulate in service trenches and manholes so where these form a gas migration pathway, they should be sealed as a gas-tight seal. CIRIA Report 149 *Protecting development from methane* describes methods of sealing service trenches and manholes.

3.4 Membrane/damp-proof course details
3.4.1 Gas membrane NOT suitable as a damp-proof course

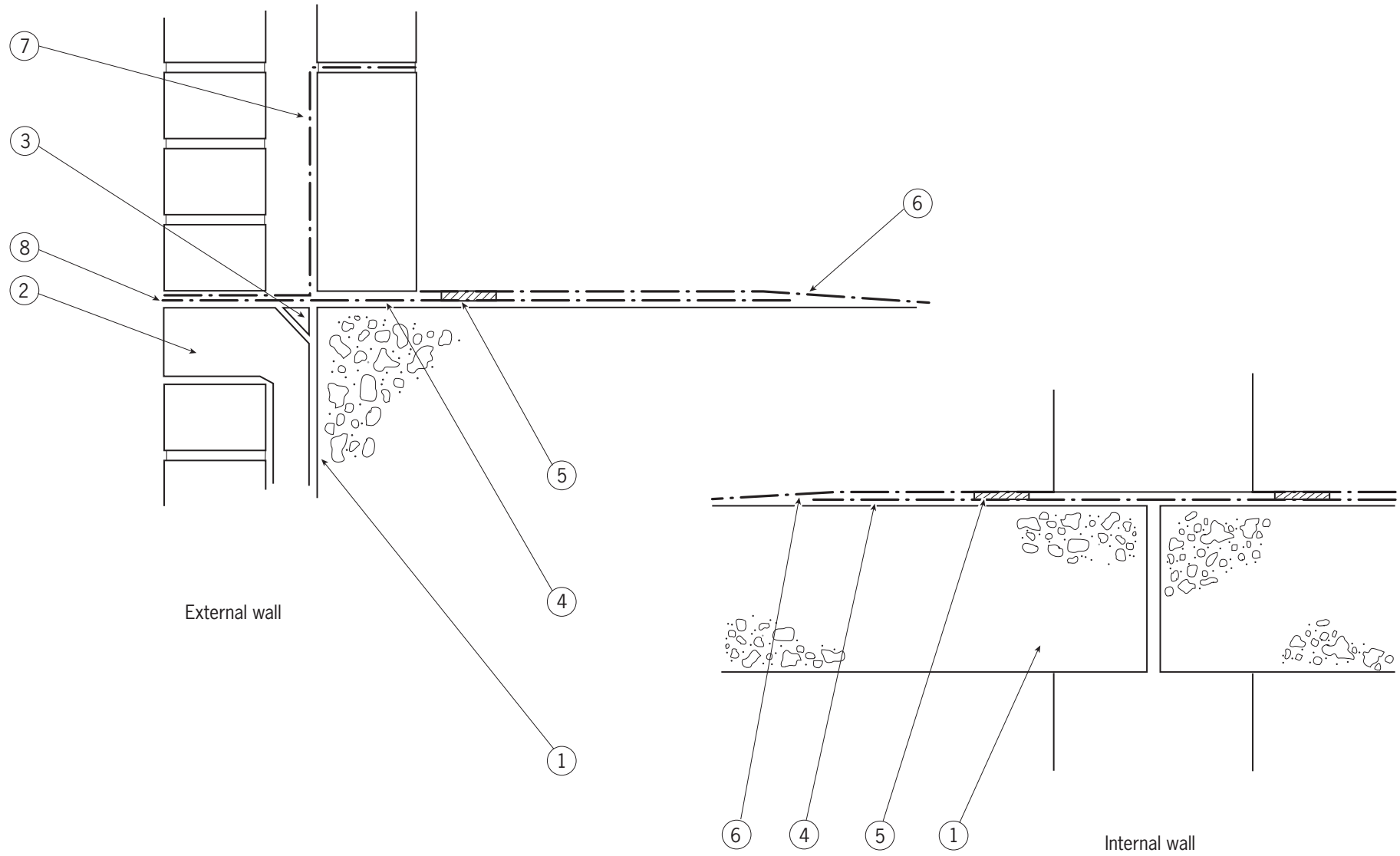

3.4 Membrane/damp-proof course details

3.4.1 Gas membrane NOT suitable as a damp-proof course

Some gas membranes do not comply with the appropriate British Standards for damp-proof courses and should not be used to resist damp penetration. The manufacturer of the gas-resistant membrane will be able to advise if the membrane is suitable to perform as a damp-proof course and complies with the appropriate British Standards. This detail illustrates how a gas-resistant membrane which should not be used to resist damp penetration can be used in conjunction with a separate approved damp-proof course.

Construction details

- 1 Slab.
- 2 Periscope ventilator or air-brick.
- 3 Fillet to support membrane (could be extruded plastics foam).
- 4 Gas-resistant damp-proof course.
- 5 50 mm double-sided sealing tape or butyl bonding strips.
- 6 Gas-resistant membrane.
For minimum overlap for tape jointed membranes see manufacturer's recommendations.
- 7 Cavity tray or self-adhesive flashing.
- 8 Seal (areas of high wind exposure).

Watchpoints

- The leading edge of the damp-proof course left projecting beyond the internal face of the wall should be protected with boarding until the gas-resistant membrane is laid. It should then be thoroughly cleaned, dried and repaired before laying the gas-resistant membrane and sealed with the 50 mm double-sided sealing tape or butyl bonding strips.
- Cavity tray to be in continuous lengths or lapped and bonded to manufacturer's recommendations or alternatively self-adhesive sheet may be used. The cavity tray should be supported over the cavity with concrete cavity fill or foamed plastics inserts.

3.4 Membrane/damp-proof course details

3.4.2 Membrane suitable as damp-proof course

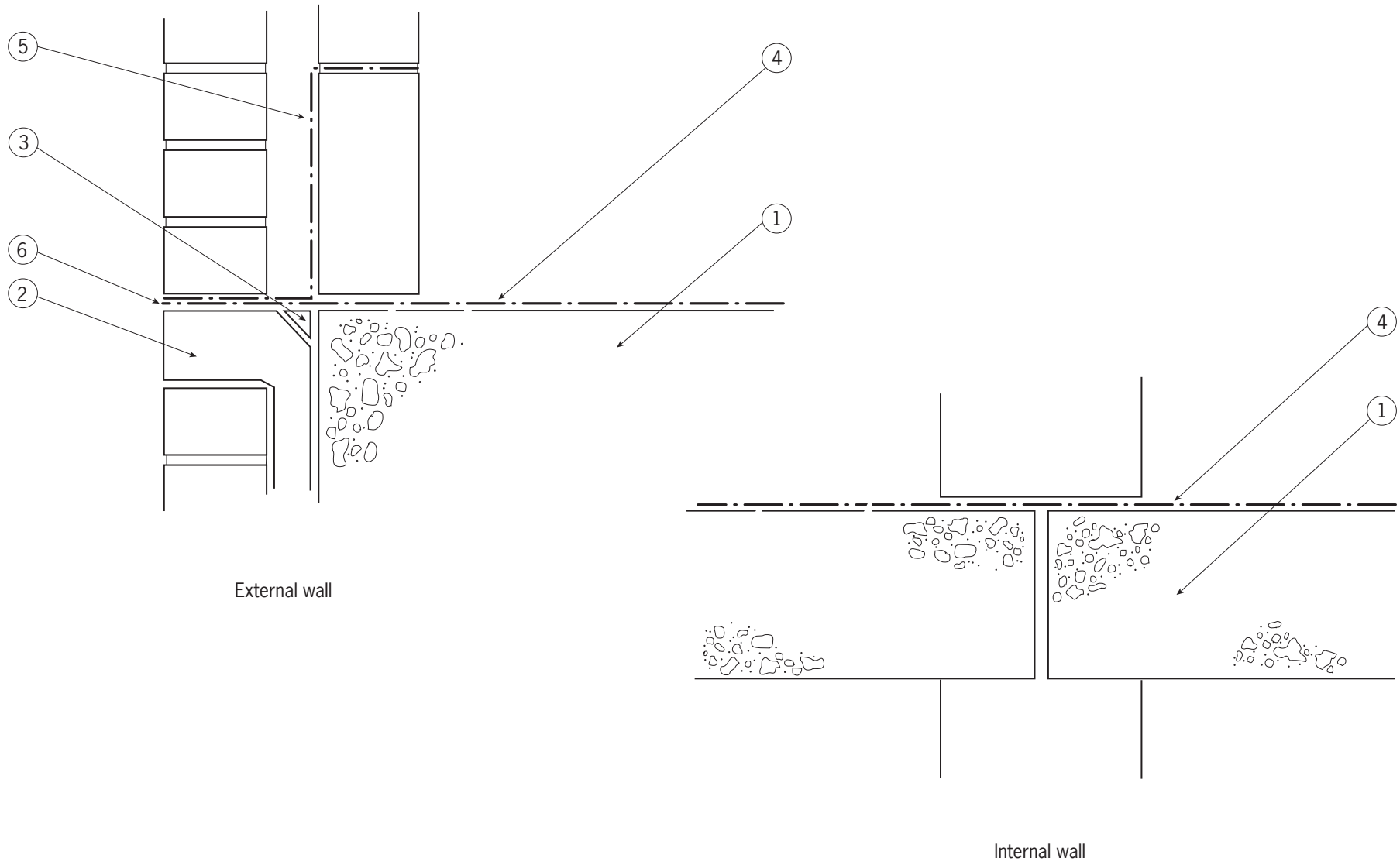

3.4 Membrane/damp-proof course details

3.4.2 Membrane suitable as damp-proof course

Some gas membranes do not comply with the appropriate British Standards for damp-proof courses and should not be used to resist damp penetration. The manufacturer of the gas-resistant membrane will be able to advise if the membrane is suitable to perform as a damp-proof course and complies with the appropriate British Standards. This detail illustrates how a gas-resistant membrane which complies with the appropriate British Standard for a damp-proof course can be used to perform the function of gas-resistant membrane and damp-proof course.

Construction details

- 1** Slab.
- 2** Periscope ventilator or air-brick.
- 3** Fillet to support membrane (could be extruded plastics foam).
- 4** Gas-resistant membrane.
- 5** Cavity tray or self-adhesive flashing.
- 6** Seal (areas of high wind exposure).

Watchpoint

- Cavity tray to be in continuous lengths or lapped and bonded to manufacturer's recommendations; alternatively self-adhesive sheet may be used. The cavity tray should be supported over the cavity with concrete cavity fill or foamed plastics inserts.



4 Gas protective measures for extensions

Residential buildings are often extended, altered or modified during their service life. This may take the form of constructing a conservatory or extension, converting the building for a change of use, or even simple modifications such as the construction of a patio.

Any modification to the fabric of the building may affect the performance of the gas protective measures. For example:

- Raising ground levels resulting in blocking ground level vents.
- Interrupting the continuity of the gas-resistant membrane thereby introducing direct gas entry into the building. Forming a continuous membrane with an effective seal is essential at the junction between the existing construction and an extension.
- Preventing or reducing the natural fresh air supply to the passive venting system resulting in inadequate dilution and dispersion of gas or modifying the preferential pathways. This could include blocking air-bricks or laying tarmac for driveways over venting trenches.
- Changing the plan configuration of the building can affect the air flow around the building. For example, an extension may alter the wind pressure acting on the structure as a whole. A reduction in the positive wind pressure on the windward and suction on the leeward sides of the building may result in less air flow through ground level vents.
- Altering the gas regime in the ground during, for example, the construction of foundations.

In BRE Report 211, extensions to dwellings are required to have either full or basic radon protection depending on the radon risk of the area concerned. If a dwelling already has radon protection then the extension must have comparable protective measures. For further details see BRE Good Building Guide 25 *Buildings and radon*.

In general terms, the gas protective measures that are applied to extensions and conversions are similar to those for new build, except the actual construction detailing is site specific. Therefore, when designing an extension, conservatory or any modification it is necessary to check the design of the original gas control system. If any part of the original system in the existing building is reduced, the existing measures should be enhanced and additional measures introduced to compensate.

4.1 Beam-and-block floor with open void (see also Detail 3.1.1)

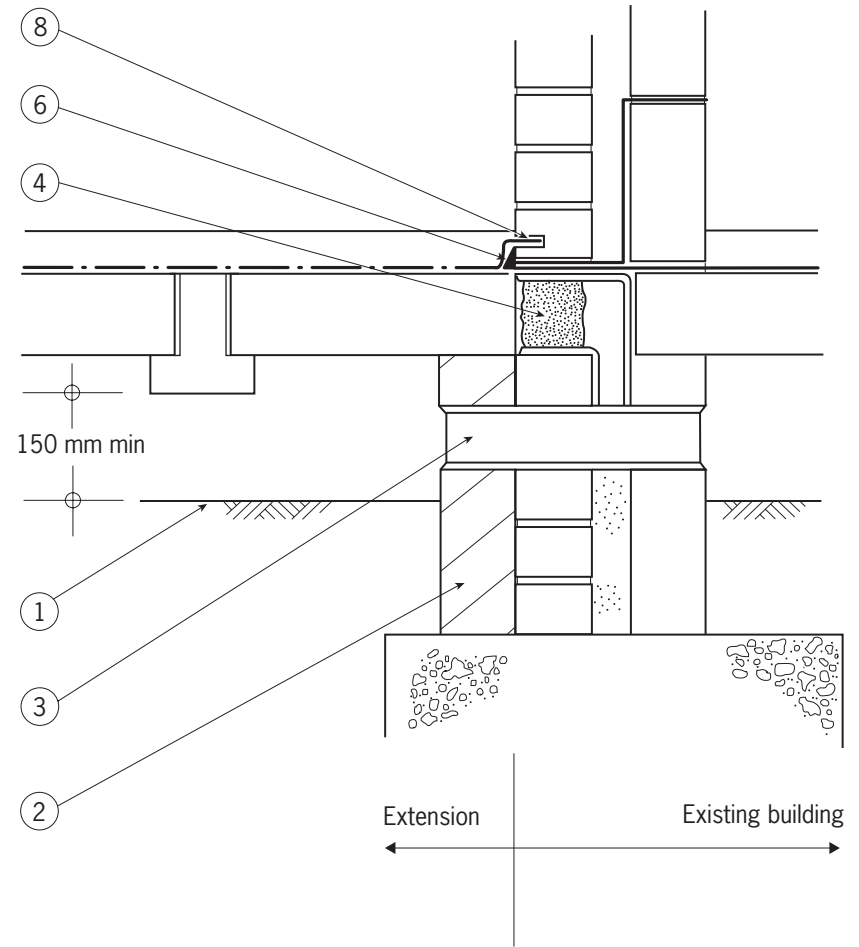
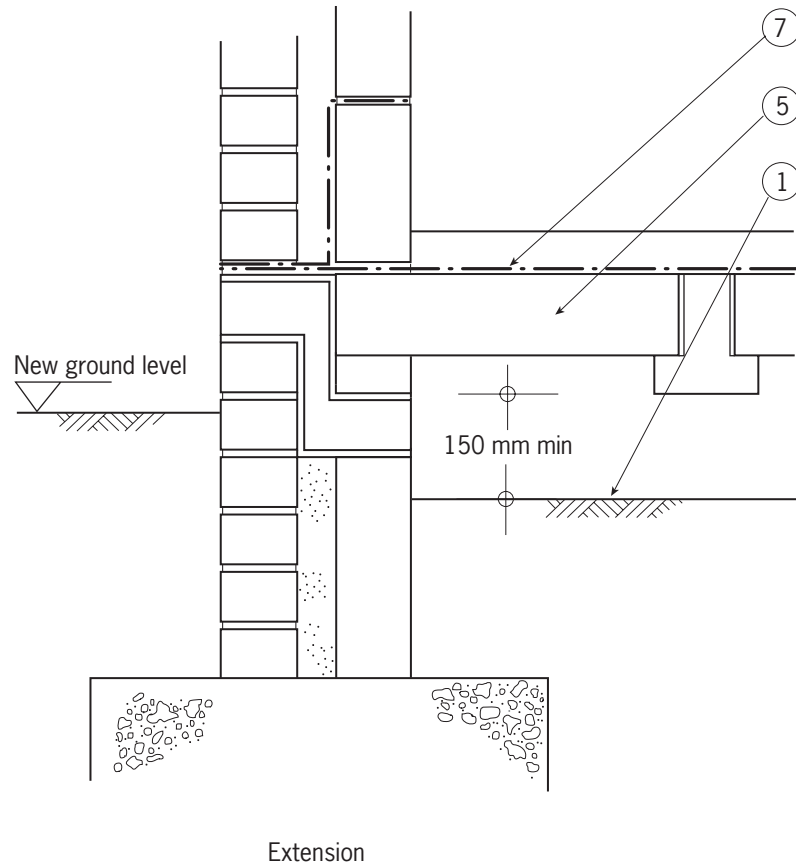

4.1 Beam-and-block floor with open void (see also Detail 3.1.1)

Construction details

- 1 External ground level reduced to minimum 150 mm below the soffit of the floor beam.
- 2 New supporting wall built off the existing foundation. Check if the foundation is adequate. Widen and/or underpin the foundation if necessary.
- 3 Form a new opening in the existing supporting wall for new straight through ventilator or air-brick with sleeve. Seal around ventilator with polyurethane foam sealant.
- 4 Seal existing periscope vent.
- 5 Construct beam-and-block floor – see Section 3.1.
- 6 Sand:cement fillet.
- 7 Gas-resistant membrane.
- 8 Gas-resistant membrane tucked into chase cut in the existing wall and sealed with a suitable gun-applied sealant.

Watchpoint

- ☐ Generally as Sections 3.1.1 and 3.4.2.

4:2 Suspended in-situ concrete slab (see also Detail 3:2:1)

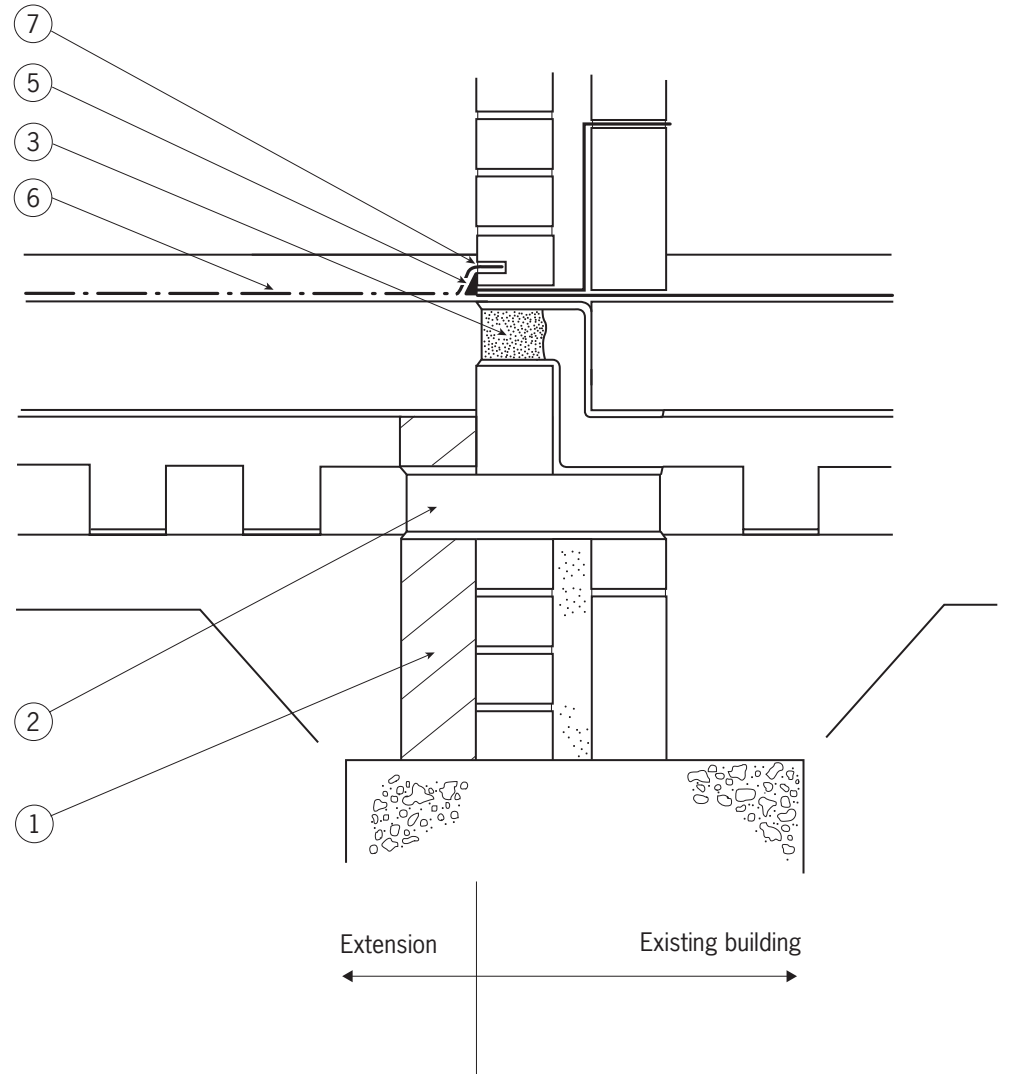
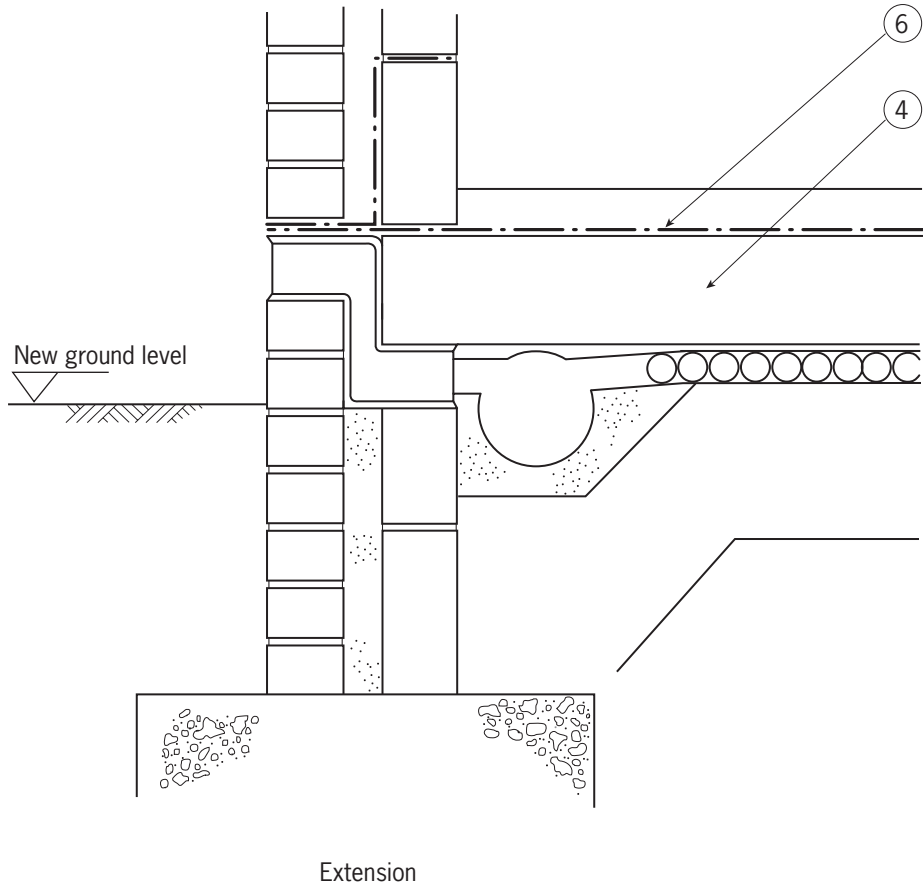

4:2 Suspended in-situ concrete slab (see also Detail 3:2:1)

Construction details

- 1 New supporting wall built off the existing foundation. Check that the foundation is adequate. Widen and/or underpin the foundation if necessary.
- 2 Form a new opening in the existing supporting wall for the new straight-through ventilator or air-brick with sleeve. Seal around ventilator with polyurethane foam sealant.
- 3 Seal existing periscope vent.
- 4 Construct new in-situ reinforced concrete suspended slab over proprietary geocomposite drainage blanket or expanded polystyrene void former.
- 5 Sand:cement fillet.
- 6 Gas-resistant membrane.
- 7 Gas-resistant membrane tucked into chase cut in the existing wall and sealed with a suitable gun-applied sealant.

Watchpoint

- Generally as Sections 3.2.1 and 3.4.2.



5 Remedial measures in existing buildings

Only recently have gas protective measures been incorporated into residential buildings. Therefore, many older properties have not benefited from any protection unless they have been installed as remedial measures. Some existing residential developments have been constructed either over or close to gassing ground.

Sites affected by gas will be identified as local authorities develop their inspection strategies as required by Part IIA of the Environmental Protection Act 1990. The risks posed by gas will be assessed and if they are significant this may lead to the installation of remedial measures in existing buildings.

5.1 Methods of remediation

As with new residential buildings, it is necessary to fully characterise the gas regime of the site (Section 1.1) and select and design a suitable gas protective system. If a passive system is considered a suitable solution there are two primary methods of providing gas remediation:

- Installing a gas-resistant membrane and/or using other sealing methods to inhibit the ingress of the gas through the ground floor and into the building. The principles of installation are described in the preceding sections. As an alternative to installing a membrane, simple remediation measures can be used, for example sealing the top of a floor. This is an option where gas entry routes are obvious, for example beneath the skirting board or around a service pipe.
- Introducing an open void or other method of diluting and dispersing the gas that may accumulate beneath the building. The principles are described in the preceding sections. It is worth noting that providing vent pipes can further enhance the ability of the venting layer to disperse the gas. If there is no cavity insulation, perpendicular ventilators can be constructed just above the damp-proof course and at eaves level. The vents will ventilate the cavity and disperse any accumulated gases.

An alternative to using a passive system is to use a proprietary positive air pressure system. A common cause of soil gas entry into a building occurs due to the lower air pressure indoors with respect to outdoors – see Section 2.1. A positive air pressure system pumps air into the sealed open void beneath the ground floor to create a zone of positive pressure. This significantly reduces the soil gas entry into the building. The pressurisation equipment does require periodic maintenance.

In the case of radon, air can be drawn out from beneath the floor (sub-floor depressurisation). This approach is unsuitable for landfill gas because of the risk of explosion. The bibliography on page 66 includes publications that describe radon remedial measures.

Although the basic principles of remedial measures in an existing residential building can be applied to a variety of building types, each case has to be considered on its merit taking into account the gas regime at the site, the construction of the existing building and any identified points of gas entry. Householders' concerns and requirements are also very important and they should be consulted at all stages.

5.2 Constraints

There are considerably more constraints to introducing remedial measures into an existing building than installing a similar system into new build.

These constraints can result in gas remedial systems that are less effective in practice than those installed in new build construction. Therefore practical detailing and skilled supervision are essential. As a consequence, it may be more appropriate to install active solutions rather than passive solutions since this may reduce the level of disruption.

Some of the constraints are:

- The layout of the existing foundations and loadbearing walls together with services will considerably restrict the options for providing effective gas remediation. Restricted access within a building limits the opportunity for installing continuous gas-resistant membranes resulting in jointing with the membrane dressed into existing walls. The joints in the membrane and forming the chases required to dress the membrane into the walls are potential leakage points. It is also difficult to install continuous ventilation beneath a slab.
- Existing buried services and their entry points to buildings are a primary gas migration route and can hinder access and reduce the potential for installing a continuous membrane and unhindered ventilation beneath the slab.
- A further difficulty is the disruption to the occupants of the building. Such disruption may involve the occupants moving into temporary accommodation during the duration of the work. In all such work it is very important to note the concerns of the householders who can have a considerable influence on the extent and form of the remedial measures.
- Existing concrete floor slabs require careful inspection. Uneven settlement and poor quality concrete often results in random cracking with some cracks penetrating to the full depth of the slab. If the slab is cracked but structurally sound, it could be treated with a flooring-grade asphalt screed or a mechanical sub-floor positive pressure system – see Section 5.1. In extreme cases, total replacement of the floor slab may be the only effective solution.
- If an existing floor is completely removed, the existing walls will need to be chased to receive the new slab and a void excavated below slab level. A continuous ventilation layer with ground level vents can then be installed with a new concrete slab built into the existing walls with a gas-resistant membrane. In practice this form of remediation could raise the ground floor levels thereby reducing the floor to ceiling height. In addition cutting chases in loadbearing walls can result in potential structural instability. If major structural work is undertaken to install a gas remedial system there is the added likelihood that cracking will occur in the existing fabric of the building creating additional migration pathways.

5.3 Venting the sub-floor and sealing the concrete oversite

Construction details

- 1 Existing concrete oversite broken out; excavate a sump approximately 400 x 400 x 400 mm.
- 2 Fill the excavation with crushed rock or crushed concrete – see Section 8 for specification.
- 3 110 mm UPVC pipe with minimum bends inserted through hole broken through existing wall.
- 4 Existing wall reinstated around pipe and sealed with a suitable gun-applied sealant.
- 5 Vent cowl on a vertical riser cranked around the eaves.
- 6 Fibreboard permanent formwork.
- 7 Grout check membrane.
- 8 Paint the exposed concrete with neat polymer or polymer-modified cement grout, then reinstate the concrete slab.
- 9 Small cracks in the existing slab to be sealed with polyurethane roofing paint. Larger cracks should be cleaned and repaired with a suitable flexible filler. If the concrete is badly cracked over a large area and in poor condition, it may need to be replaced – see Sections 3.1 and 3.2.
- 10 Before replacing skirting, force sealant into the gap and form a fillet with the sealant between the floor slab and the wall.

- 11 Gas-resistant membrane dressed into a continuous chase cut in the existing wall and sealed and protected immediately after installation
- 12 Gas-resistant membrane
- 13 Screed and insulation
- 14 Proprietary cavity vents installed just above the damp-proof course and just below eaves at centres recommended by the manufacturer
- 15 Cavity sealed with polyurethane foam sealant.

Watchpoints

- Generally as Section 3.2.1.
- Construction suitable only for low levels of gas contamination.
- Service runs (gas, water etc.) should be located and avoided before breaking out the slab.
- The vertical riser should discharge above eaves level and not adjacent to window, rooflights and roof level air intakes or vents and other apertures in the external envelope of the building. Risers should be kept as straight as possible.
- The primary gas migration route into the building occurs through the service entries and so particular care must be taken with producing a gas-tight seal at all service entries.
- Internal vertical risers are used for radon remedial measures but it is suggested that they are not used where methane, carbon dioxide and associated gases are concerned.

5.4 Service entries

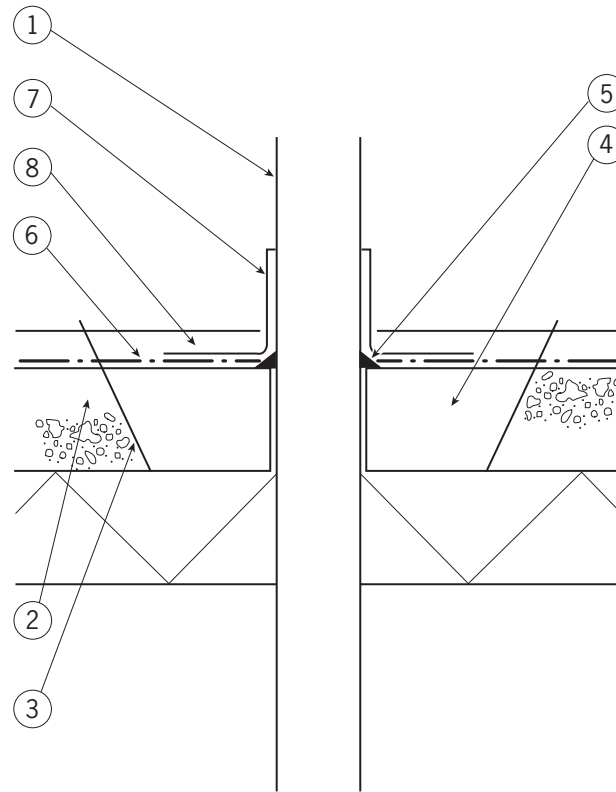

Typical service entry

5.4 Service entries

Construction details

- 1 Existing or new service pipe.
- 2 Break out existing concrete oversite.
- 3 Paint neat polymer or polymer-modified cement grout onto exposed concrete.
- 4 Backfill with polymer-modified mortar.
- 5 Sand:cement fillet.
- 6 New gas-resistant membrane.
- 7 Proprietary top-hat. The top-hat may have to be installed in sections, overlapped or site-welded or the service pipe cut and new joint formed on completion.
- 8 New screed and insulation.

Watchpoints

- Service entries are often located close to walls. The top-hat should be installed before the wall is constructed above slab level. The 'rim' of the top-hat is laid in the bed joint and sealed to the damp-proof course before the next course of masonry is laid.
- If possible, services should enter the building above slab level to avoid penetrating the gas-resistant membrane. However, the water service and soil pipes will usually be required to enter the building through the slab and membrane.
- Top-hat diameter should match service pipe diameter. There may be the need to construct the proprietary top-hat in sections, overlapped and site-welded.
- The number of services entering the building through the ground floor must be kept to a minimum.
- To service each flat in a flat development, it is common for 'clusters' of service pipes to penetrate the ground floor. These are difficult to seal and should, therefore, be avoided. Service entries, for example water and electricity, should be single entry points to each individual flat above the ground-floor level. The remaining services, including telecommunications, should enter above ground and then laid in service trays constructed in the floor slab.
- See also Section 10 for more details.



6 Specific details – gas-resistant membranes

The function of a low-permeability, gas-resistant membrane is to prevent gas entry through the ground-floor construction into the building through shrinkage cracks, joints and service entries as described in Section 2.1. If possible, therefore, the membrane should be laid continuously over the whole plan area of the building, including the external cavity walls. If joints are required, the membrane should be lapped according to manufacturer's recommendations and joint sealed with double-sided self-adhesive tape rolled to provide a positive seal. Alternatively, the laps can be site-welded. If the joints are overlapped and site-welded, care is needed to avoid damaging the membrane during welding.

6.1 Types of membrane

Polyethylene is the principal material used as a gas-resistant membrane. It is marketed in a variety of thicknesses and can be reinforced with grids or screens of high-density polyethylene, polypropylene or polyester to improve the durability of the material during the construction process. The permeability of the membrane can be reduced by introducing a layer of aluminium foil.

Typical thicknesses in mm are:

Polyethylene	0.3 to 1.0
Reinforced polyethylene	0.3
Reinforced polyethylene with aluminium foil	0.3 to 0.8
Polyethylene with aluminium foil and polymerised bitumen	0.3 to 1.5

The minimum thickness of polyethylene used as a gas-resistant membrane is 1200 gauge or 0.3 mm thick.

When selecting a gas-resistant barrier, it is important to consider the ability of the membrane to withstand damage during installation. In general, for unreinforced membranes, the thinner the material, the more susceptible it is to mechanical damage, although small tears can be repaired

The performance of a gas-resistant membrane is dependent upon its ability to withstand the rigours of installation rather than permeability. Therefore, the membrane must be resistant to puncture, abrasion and tearing, and ultraviolet light which may cause embrittlement of the membrane if it is left exposed for longer than the normal construction period.

6.2 Advantages and limitations

Since no membrane is totally impermeable to gas, it should be used in conjunction with other gas mitigation components, for example a concrete slab or gas venting layer. With careful design and selection of materials the membrane will satisfy the dual function of damp-proofing and gas protection.

The performance of the membrane as a gas barrier is significantly reduced if the membrane is punctured, torn or not adequately lapped and sealed during construction. To reduce the risk of damage to the membrane, the methods and sequence of construction should be considered in the selection of the membrane for each project. Quality control procedures should be adopted throughout the installation of the membrane: these may include third party integrity testing – see Section 6.3.

6.3 Integrity testing

The need for high quality workmanship during the installation of the gas-resistant membrane should not be under-estimated. The health and safety of the occupants of the building is dependent on its satisfactory performance. The most effective method of achieving high quality workmanship is to employ specially trained quality assured teams who follow best practice guidance. Ideally their work should be subject to third-party inspection, for example by the building control inspector.

If there are doubts upon the quality of the installation, post-installation integrity testing of the membrane and joints may be undertaken. Any leaks found in the membrane or the joints should be sealed before construction continues. Although there are several non-destructive test methods, for example vacuum box, air pressure, ultrasonic or air lance, they all have shortcomings when applied to post-installation gas membranes. The most effective post-installation test method is to pressurise the underside of the membrane with an appropriate tracer gas and then sweep the top surface with a suitable gas-detection device. The advantage of this method is that the whole membrane including joints are tested. It has been demonstrated that this test method can detect even very small gas migration routes in the membrane

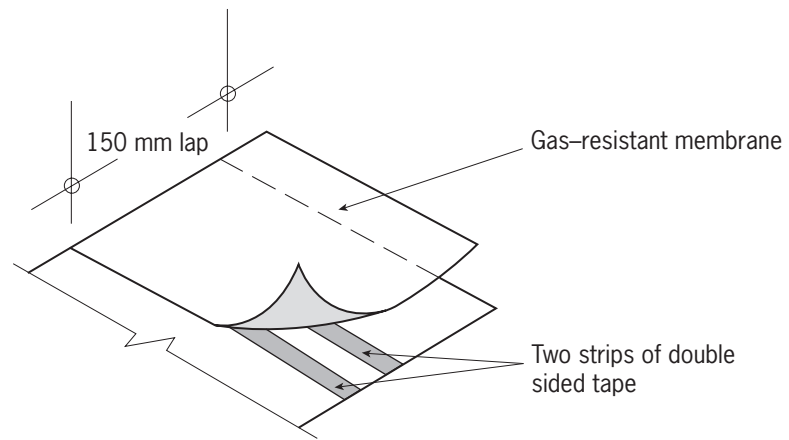

Lapping the gas-resistant membrane

6.4 Protection during construction, jointing and sealing

Before installing a membrane, the manufacturer should be informed of the site conditions so that the manufacturer can supply a membrane suitable for the specific site conditions. Before the membrane is installed the manufacturer's instructions should be consulted and any specific details and specifications made available to the site operatives

Watchpoints

- ❑ Endeavour to lay the membrane flat. If possible, avoid steps and corners: use proprietary components at these locations.
- ❑ Loose lay the membrane on to a clean surface that is free of any projection or sharp objects.
- ❑ All laps and joints should be in accordance with the manufacturer's recommendations and, ideally, joint sealed with double-sided, self-adhesive tape rolled to provide a positive seal. Alternatively, the laps can be site-welded. If the joints are overlapped and site-welded, take care to avoid damaging the membrane during the welding operation.
- ❑ The tape can be used together with a patch of equivalent membrane to repair punctures or tears in the membrane.
- ❑ High-quality proprietary tape:
 - for radon protection:*
two strips 15–30 mm wide
 - for methane and/or carbon dioxide protection:*
one strip 50–75mm.
- ❑ Tape will not adhere to wet or damp surfaces. If the surface is wet, dry it first using a warm-air dryer (or hair dryer).
- ❑ The gas-resistant barrier should be continued across cavity walls and internal walls.
- ❑ The membrane should be covered with the permanent overlying construction (screed) as soon as possible.
- ❑ The sealant or stabiliser laid as a primer on the floor slab should be chemically compatible with the membrane.
- ❑ An alternative to double-sided tape is butyl bonding strips. Butyl bonding strips may be more damp tolerant than tape.



7 Specific details – venting the sub-floor

The purpose of venting the sub-floor is to provide a ventilated zone where soil gases are diluted and dispersed.

The sub-floor can be constructed using the following methods:

- An open void space.
- Proprietary void formers, such as expanded polystyrene or geocomposite systems.
- Granular blankets comprised of permeable aggregates.
- Granular blankets with perforated pipe or geocomposite drain networks.

The design of the sub-floor ventilation layer should avoid creating areas of low or zero air movement. This is achieved by connecting the ventilation layer to the external envelope of the building by vents. Various types of vents are described below.

An alternative to using side vents is to construct a pipe through the external wall but the pipe entry through the wall is a potential gas migration pathway into the cavity unless the external surface of the pipe is sealed on both the internal and external surfaces. The pipe enables gas collected beneath the building to vent harmlessly outside the building.

7.1 Air-bricks

Whether the gas venting layer is a void, granular blanket or a proprietary void former, the provision of sufficient vent openings situated on the perimeter and internal walls of the building is critical to the efficiency of the sub-floor system. Table 6 in BS 5925: 1991: *Ventilation principles and designing for natural ventilation*, provides useful guidance on the types of air-brick and their equivalent areas of opening.

The location and spacing of the air-bricks should conform to relevant statutory and mandatory requirements, for example the Building Regulations and NHBC Standards.

The configuration of some buildings (such as narrow-fronted terraced housing, often with integral garage) prevents the spacing of air-bricks as specified. The centres of the air-bricks should, therefore, be reduced to ensure there is through-ventilation of the open void.

Where an access ramp is situated adjacent to the external wall as required by Part M of the Building Regulations, the air-bricks should be spaced and detailed to ensure through ventilation of the void.

7.2 Periscope vents

The detailing below the damp-proof course on a typical dwelling can become quite complex with a variety of criteria to satisfy, for example coursing of the brick and blockwork, damp-proofing and providing gas protection. Therefore, incorporating a proprietary periscope vent is particularly useful if the underside of the venting layer is lower than the external ground level. The slide to the periscope vent should be sealed with proprietary tape after it has been adjusted to the required length.

7.3 High-level stacks

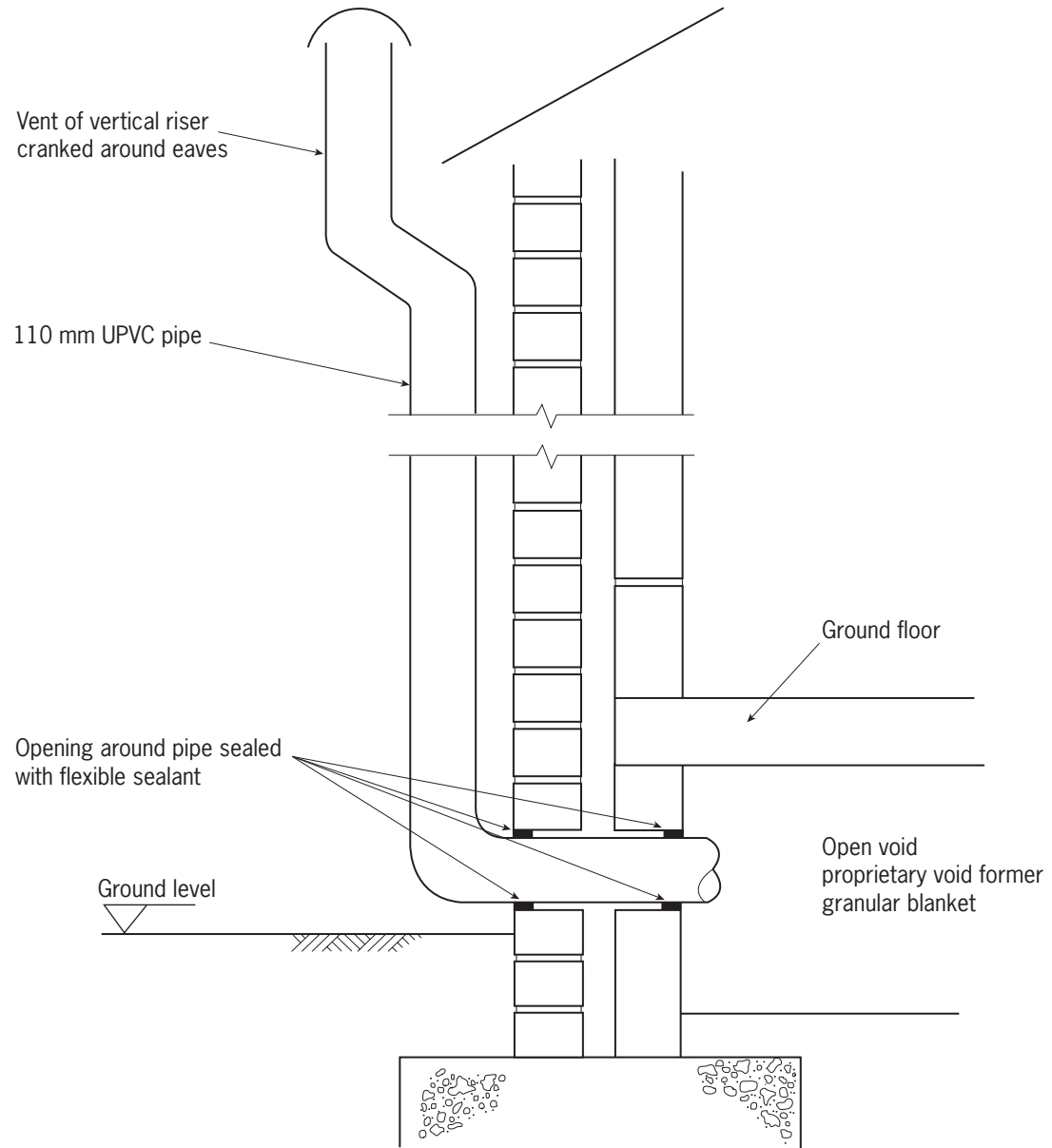

7.3 High-level stacks

High-level vent stacks provide an alternative method of venting the sub-floor. They are particularly useful where obstructions or other factors are likely to prevent ground-level vents operating effectively. Although a vertical riser is an efficient method of ventilating the sub-floor void, it does affect the external aesthetics of the dwelling unless it is disguised as a rainwater pipe or built-in brick piers.

The vertical riser is fixed to a connecting pipe that passes through the external wall from the sub-floor void. To avoid gas migrating from the sub-floor void into the cavity, sealant is forced into the gap between the connecting pipe and the wall. A 'chinese hat' or 'mushroom' type terminal can be fixed to the top of the vertical riser, although aerodynamic rotating cowls can be more efficient for generating up-flow through the stack. Advice on the performance of the ventilation cowls is in BRE Information Paper IP 6/95.

It is common practice to have the riser on the leeward side of the building with fresh air inlets at low level on the windward side. One riser could be connected to several vents in the form of a manifold.

The size and spacing of the vertical risers are dependent upon the quantity of gas likely to accumulate in the sub-floor void. Further guidance is in the DETR/Ove Arup report *Passive venting of soil gases beneath buildings*.



8 Specific details – granular blankets

Granular blankets provide an alternative method to the open void for forming a gas venting layer.

The granular blanket may be constructed either:

- beneath an in-situ concrete suspended slab supported on loadbearing walls; in this case, the long term creep settlement of the blanket is not critical;
- beneath a ground-bearing in-situ concrete slab, raft or semi-raft foundation; in this case, long-term creep settlement does have to be limited through specification of the blanket materials and the method of placement.

Gas is extracted from the granular blanket by vents constructed in the external and internal walls.

Blanket beneath an in-situ concrete suspended slab supported on loadbearing walls

The blanket should be constructed from crushed rock or concrete or natural gravels having a minimum size of 20 mm. The particles can be angular or rounded and only minimal compaction should be applied to the layer.

Blanket beneath a ground bearing in-situ concrete slab, raft or semi-raft foundation

The blanket should be constructed only from angular and sub-angular crushed rock or concrete. The particle size range should be 20 mm to 40 mm.

The blanket should be placed and compacted in layers no more than 150 mm thick. The design thickness of the blanket should take into account the width of the building, the size and permeability of the aggregate used and whether gas drains are included. Blankets would not normally exceed 600 mm in thickness, but should be not less than 300 mm without gas drains or 150 mm with gas drains at 2.0 m centres. In all cases, the thickness of the granular blanket should be at least 100 mm greater than the diameter of the gas drain.

The use of granular blankets should be restricted to sites with low groundwater level and where the underlying soils are free-draining.



9 Specific details – gas drains in granular blankets

The performance of granular blankets can be improved in large plan area buildings if slotted or perforated pipes are laid as gas drains within the blanket. However, gas drains have no significant effect and can impair performance owing to short-circuiting if laid in buildings of small plan area, for example a typical low-rise house.

A gas drainage layout should:

- avoid short-circuits between opposite faces of the building;
- encourage a uniform flow of clean air throughout the whole area of the granular blanket;
- minimise the flow path through the granular blanket

The perforated pipes should be:

- minimum diameter 100 mm;
- slot size 2 to 6 mm;
- open surface area 10 to 15%.

Proprietary geocomposite void formers can be used in strips as gas drains but they are less efficient than slotted pipe drains.

Further guidance is in DETR/Ove Arup Guide for design *Passive venting of soil gases beneath buildings*.

10 Specific details – service entries

10.1 Beam-and-block floor with open void

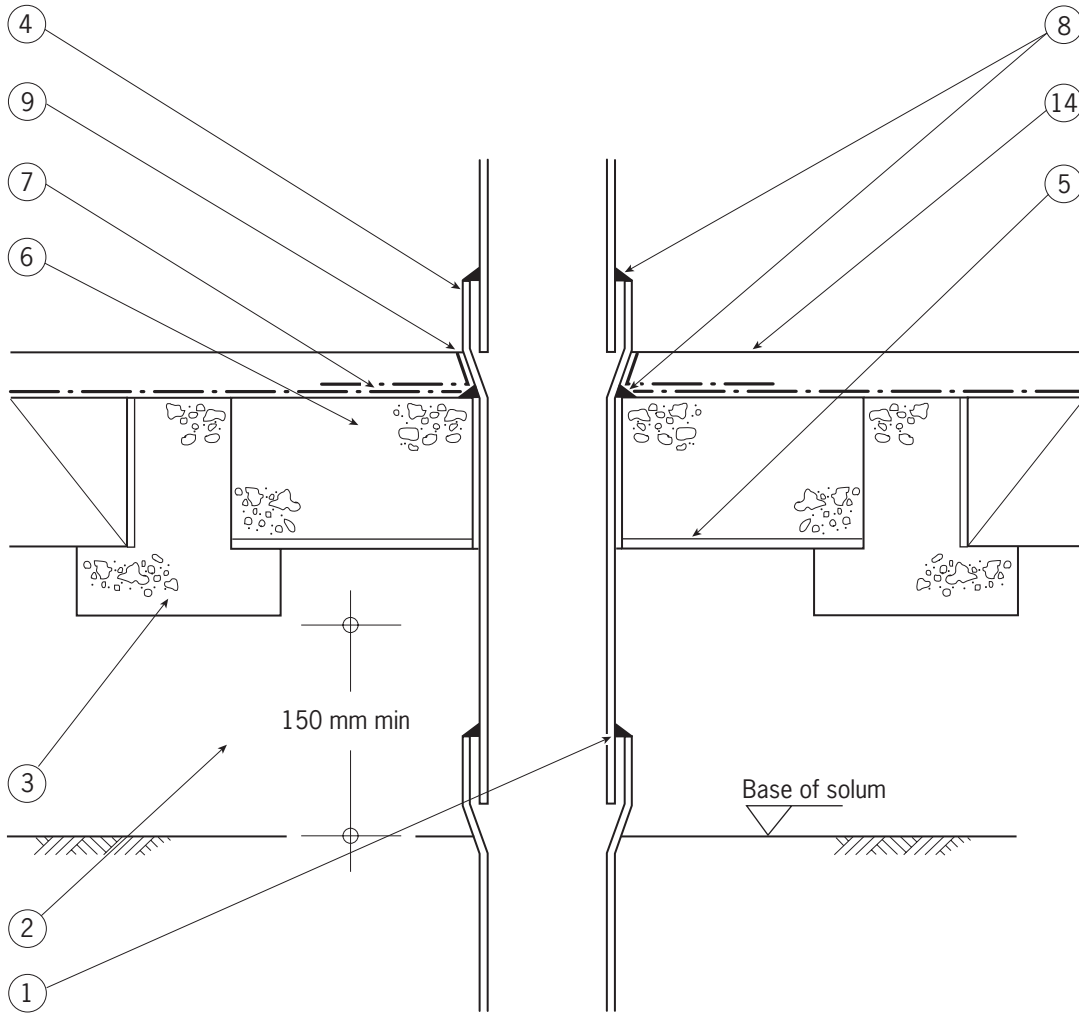

Soil vent pipe entry

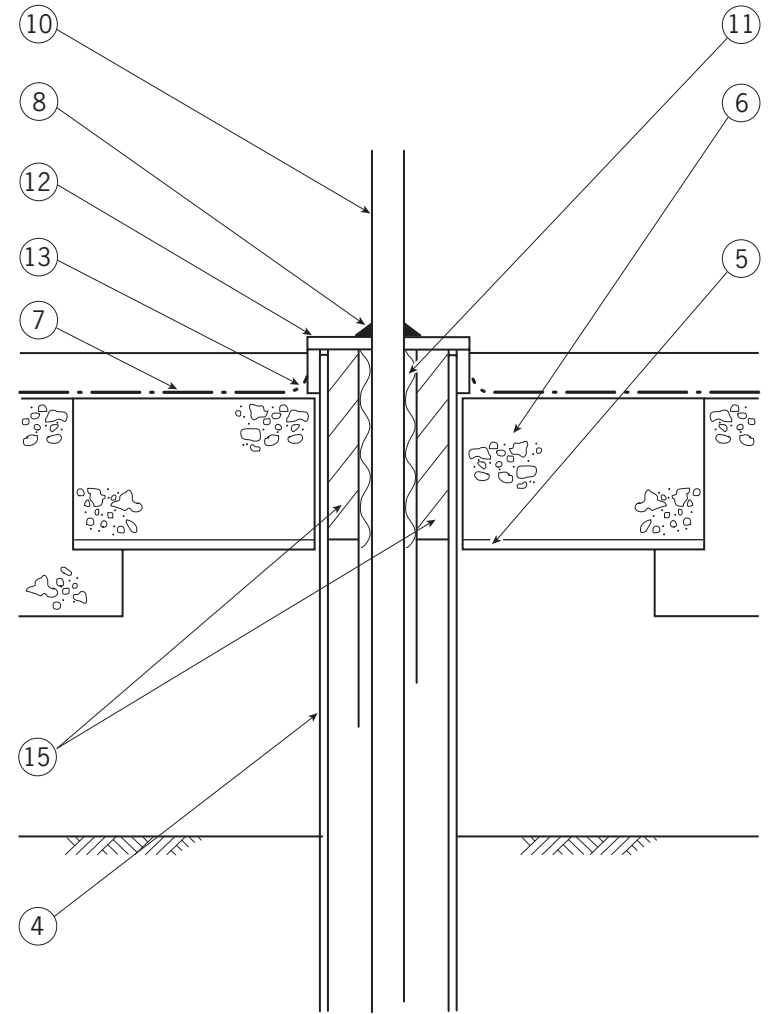

Water service entry

10.1 Beam-and-block floor with open void

Construction details

- 1 Flexible sealant.
- 2 Open void.
- 3 Beam-and-block floor – see Section 3.1.
- 4 Service duct.
- 5 Permanent formwork template with hole cut to accommodate service pipe.
- 6 In-situ concrete.
- 7 Gas-resistant membrane cut around service pipe.
- 8 Single-sided tape (for width refer to manufacturer's recommendations) or flexible sealant formed using bullnose trowel.
- 9 Proprietary top-hat.
- 10 Water service pipe.
- 11 Insulation.
- 12 Screwed pipe end with hole for water service pipe.
- 13 Membrane solvent-welded to screwed pipe end cap.
- 14 Screed and insulation.
- 15 Expanding sealant.

Watchpoints

- ❑ If possible, services should enter the building above slab level to avoid penetrating the gas-resistant membrane. However, the water service and soil pipes are usually required to enter the building through the slab and membrane.
- ❑ The number of services entering the building through the ground floor should be kept to a minimum.
- ❑ Where service entries pass through the floor slab, they are often located close to walls. The top-hat should be installed before the wall is constructed above slab level. The 'rim' of the top-hat is laid in the bed joint and sealed to the damp-proof course before the next course of masonry is laid.
- ❑ If the service entry must be close to a wall, ensure that the outside of the pipe is at least 50 mm from the face of the wall – see diagram below. The 'rim' of the top-hat is cut at the face of the wall and sealed to the gas-resistant membrane – see Section 6.4.

- ❑ Top-hat diameter should match service pipe diameter.
- ❑ Top-hat may need to be installed in sections, overlapped and taped or site-welded.
- ❑ To service each flat in a flat development, it is common for 'clusters' of service pipes to penetrate the ground floor. These are difficult to seal and should be avoided. Service entries, for example water and electricity, should be single entry points to each individual flat above the ground-floor level. The remaining services, including telecommunications should enter above ground. These services are then laid in service trays constructed in the floor slab.

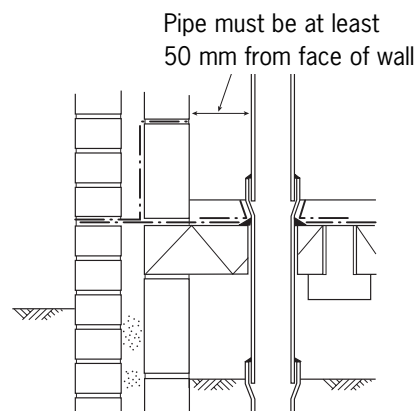

10.2 In-situ concrete slab

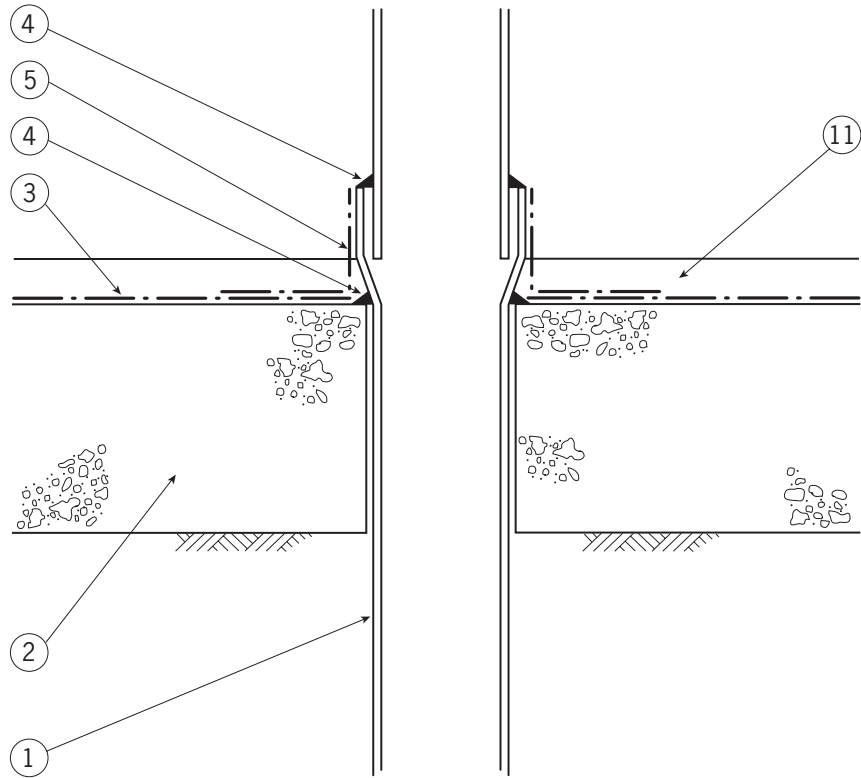

Soil vent pipe entry

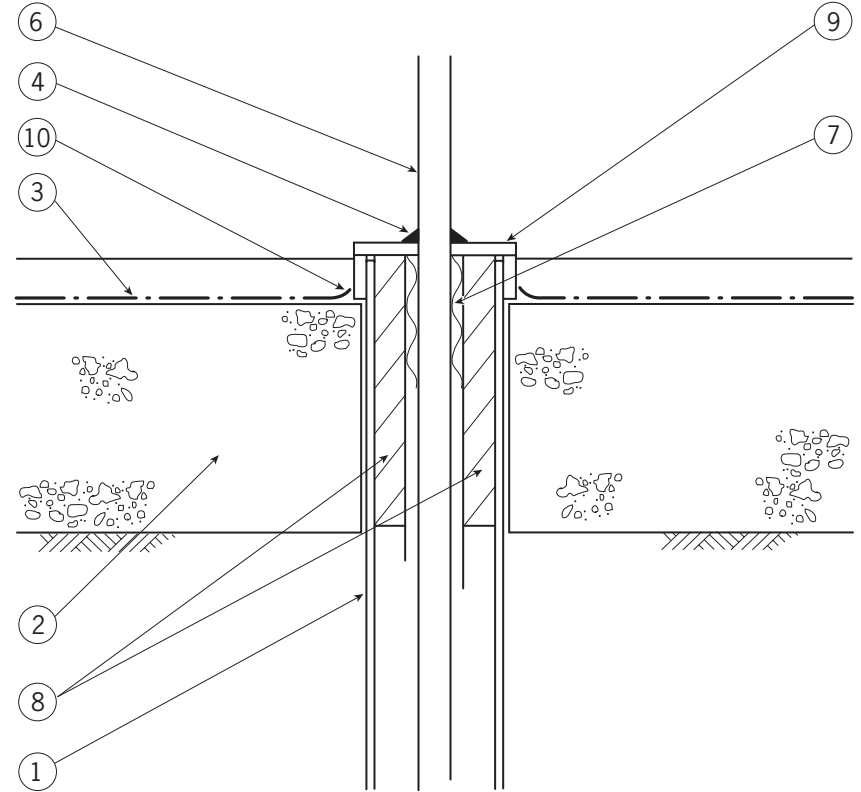

Water service entry

10.2 In-situ concrete slab

Construction details

- 1 Service duct.
- 2 In-situ concrete slab.
- 3 Gas-resistant membrane.
- 4 Single-sided tape (for width refer to manufacturer's recommendations) or flexible sealant and formed using bullnose trowel.
- 5 Proprietary top-hat.
- 6 Water service pipe.
- 7 Insulation.
- 8 Expanding sealant.
- 9 Screwed pipe end with hole for water service pipe.
- 10 Gas-resistant membrane solvent welded to screwed end cap.
- 11 Screed and insulation.

Watchpoints

- ❑ If possible, services should enter the building above slab level to avoid penetrating the gas-resistant membrane. However, the water service and soil pipes are usually required to enter the building through the slab and membrane.
 - ❑ The number of services entering the building through the ground floor should be kept to a minimum.
 - ❑ Where service entries pass through the floor slab, they are often located close to walls. The top-hat should be installed before the wall is constructed above slab level. The 'rim' of the top-hat is laid in the bed joint and sealed to the damp-proof course before the next course of masonry is laid.
 - ❑ If the service entry must be close to a wall, ensure that the outside of the pipe is at least 50 mm from the face of the wall – see diagram on page 57. The 'rim' of the top-hat is cut at the face of the wall and sealed to the gas-resistant membrane – see Section 6.4.
 - ❑ Top-hat diameter should match service pipe diameter.
 - ❑ Top-hat may need to be installed in sections, overlapped and taped or site-welded.
- ❑ To service each flat in a flat development, it is common for 'clusters' of service pipes to penetrate the ground floor. These are difficult to seal and should be avoided. Service entries, for example water and electricity, should be single entry points to each individual flat above the ground-floor level. The remaining services, including telecommunications should enter above ground. These services are then laid in service trays constructed in the floor slab.

10.3 Sealing service ducts

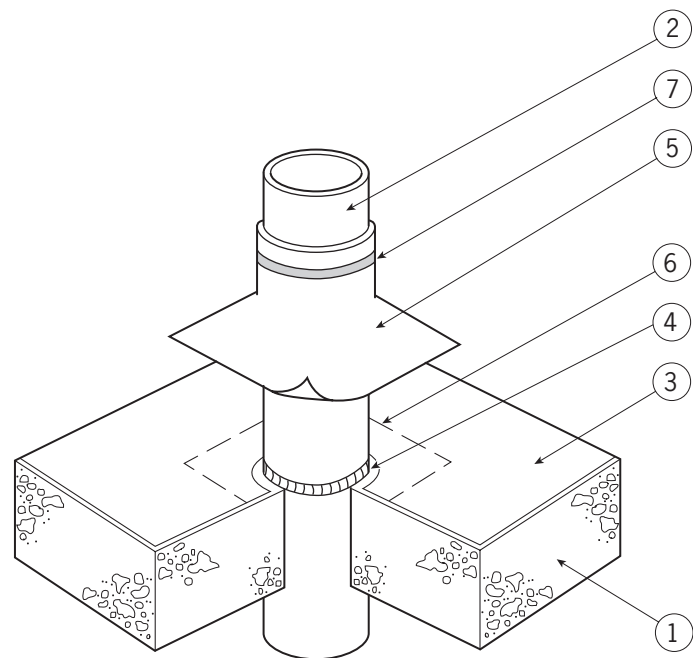

10.3 Sealing service ducts

Construction details

- 1 Floor slab.
- 2 Service duct.
- 3 Gas-resistant membrane cut around the service duct.
- 4 Double-sided tape (for width refer to manufacturer's recommendations) or flexible sealant applied with a bullnose trowel to the duct where it penetrates the floor slab.
- 5 Top-hat slid over the service duct.
- 6 Double-sided tape to seal the 'rim' of the top-hat to the gas-resistant membrane.
- 7 Jubilee clip tightened to seal the top-hat to the service duct.

Watchpoints

- The service duct and the membrane should be kept dry.
- Although it is possible to prefabricate a top-hat detail from the gas-resistant membrane, flexible sealant and double-sided tape, proprietary top-hat systems are easier to fix and form and are a more efficient seal against gas ingress in to the building.

10.4 Top of slab services

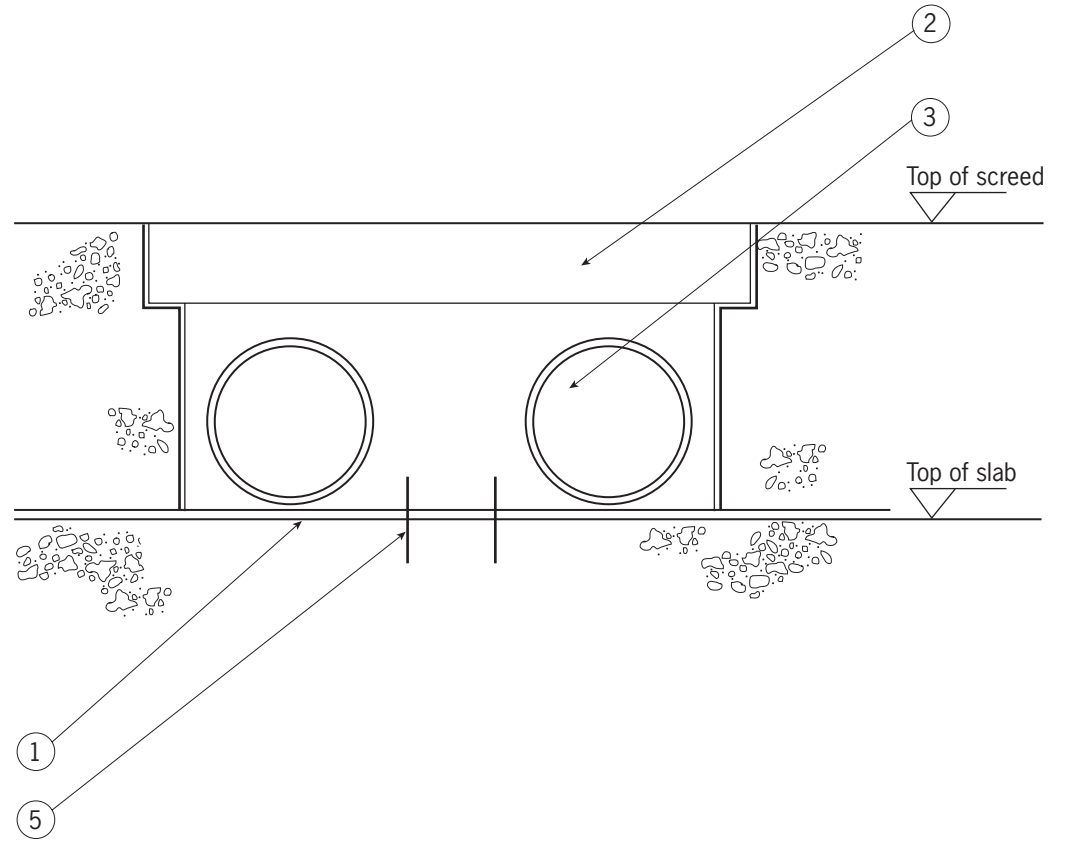
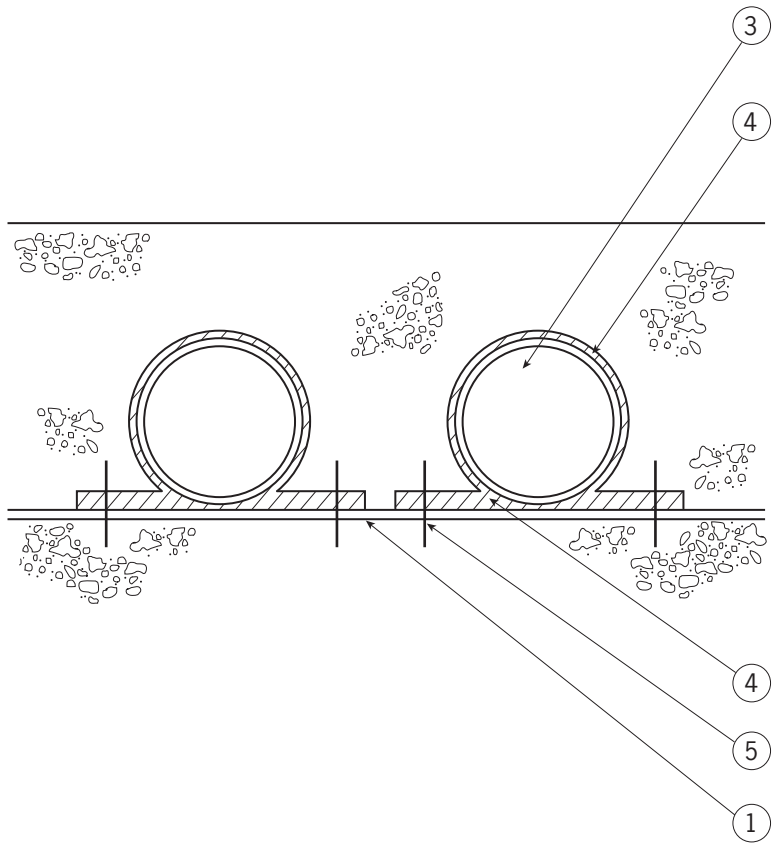

10.4 Top of slab services

Construction details

- 1 Gas-resistant membrane.
- 2 Steel duct and duct cover.
- 3 Small-bore water or gas service pipes.
- 4 Fixing brackets placed over strip of proprietary sealant tape before nailing.
- 5 Fixing nails.

Watchpoint

- The proprietary sealant tape self seals the hole formed by the fixing nail. The manufacturer of the proprietary sealant tape should confirm the tape possesses self-sealing properties before using it on site.

10.5 External service entry

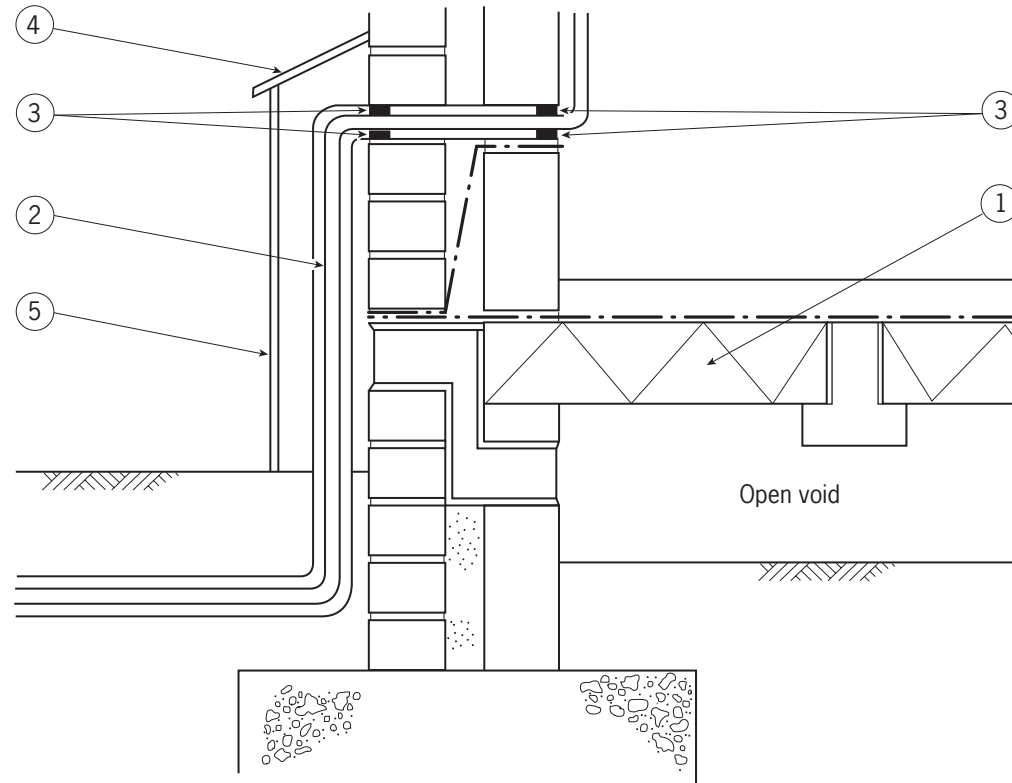

10.5 External service entry

Construction details

- 1 Beam-and-block floor with open void – see Section 3.1.
- 2 Incoming pipe/cable in duct.
- 3 Incoming service pipe should be sealed around sleeve with silicone mastic sealant.
- 4 External cover or cabinet to service inlet duct.
The cabinet should be vented at the top and bottom with a few small holes to allow circulation of air.
- 5 Duct to be vented inside external cover or cabinet.

Bibliography

BRE

Measurement of gas emissions from contaminated land. BRE Report BR 100. Garston, CRC, 1987.
Radon: guidance on protective measures for new dwellings. BRE Report BR 211. Garston, CRC, 1999, 3rd edition.
Construction of new buildings on gas-contaminated land. BRE Report BR 212. Garston, CRC, 1991.
Radon Sumps – a BRE guide to radon remedial measures in existing dwellings. BRE Report BR 227. Garston, CRC, 1998.
Sealing cracks in solid floors. BRE Report BR 239, Garston, CRC, 1993.
Protecting dwellings with suspended timber floors: a BRE guide to radon remedial measures in existing dwellings. BRE Report BR 270, Garston, CRC, 1994.
Radon: guidance on protective measures for new dwellings in Scotland. BRE Report BR 376. Garston, CRC, 1999.
Testing the performance of terminals for ventilation systems, chimneys and flues. BRE Information Paper IP 5/95.
Flow resistance and wind performance of some common ventilation terminals. BRE Information Paper IP 6/95.
Buildings and radon. BRE Good Building Guide GBG 25.

Department of the Environment and the Welsh Office (DETR)

The Building Regulations 1991 Approved Document C2. Site preparation and resistance to moisture. HMSO, 1992 edition.

Department of the Environment, Transport and the Regions (DETR)

The control of landfill gas. Waste Management Paper No 27. TSO, 1991.
Methane and other gases from disused coal mines: the planning response. Technical Report. TSO, 1996.
Accessible thresholds in new housing – Guidance for house builders and designers. TSO, 1999.

British Geological Survey

Methane, carbon dioxide and oil seeps from natural sources and mining areas: characteristics, extent and relevance to planning and development in Great Britain.
 British Geological Survey Technical Report WP/95/1, 1995.

Department of the Environment, Transport and the Regions/Ove Arup

Passive venting of soil gases beneath buildings: Guide for design. Vol 1. Partners in Technology. 1997.

Construction Industry Research and Information Association (CIRIA)

Methane: its occurrence and hazards in construction. CIRIA Report 130, 1993.
Measurement of methane and other gases from the ground. CIRIA Report 131, 1993.
Protecting development from methane. CIRIA Report 149, 1995.
Methane investigation strategies. CIRIA Report 150, 1995.
Interpreting measurements of gas in the ground. CIRIA Report 151, 1995.
Risk assessment for methane and other gases from the ground. CIRIA Report 152, 1995.

National House-Building Council

Land quality – managing ground conditions. NHBC Standards 4:1, Jan 1999.

Environment Agency/NHBC

Guidance for the safe development of housing on land affected by contamination. R&D Publication 66, 2000.

Institute of Wastes Management (IWM)

Monitoring of landfill gas. 2nd edition, 1998.

British Standards Institution

BS 5925: 1991 Ventilation principles and designing for natural ventilation
 BS 5930: 1999 Code of practice for site investigations
 BS 8102: 1990 Code of practice for protection of structures against water from the ground
 BS 8110: Part 1: 1997 Structural use of concrete: Code of practice for design and construction
 BS 8215: 1991 Code of practice for design and installation of damp-proof courses in masonry construction